

freud.

**Cutterheads and
Brazen Cutters
Teste Portacoltelli e Frese
Saldobrasate**

Catalogue - Catalogo

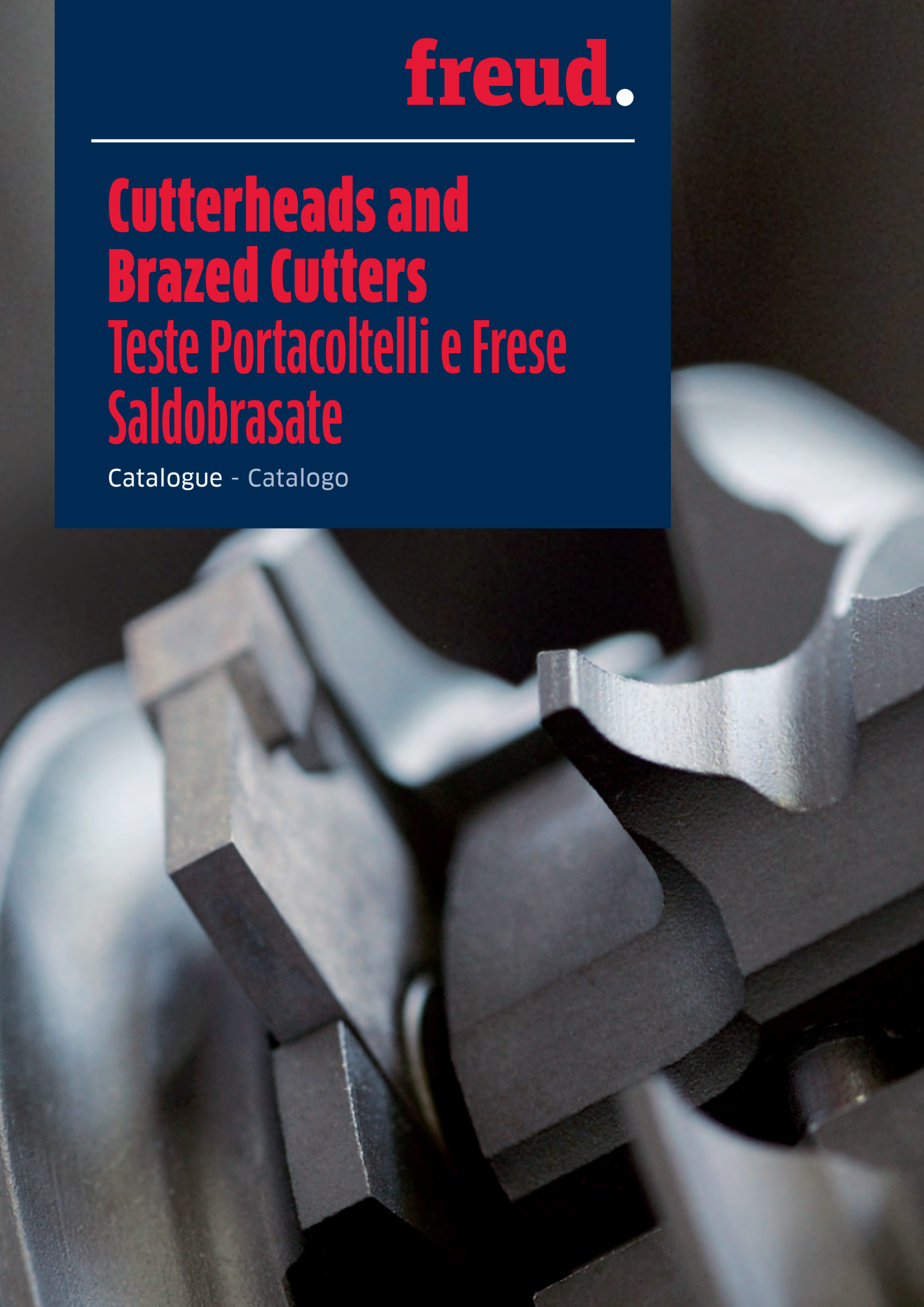

TD21M

Raised panel cutterheads Piattabande multiprofilo

This item is supplied with knives and optional cutters. Cost saving: 5 different raised panels can be produced with this cutter at a fraction of the cost of individual tools.

This item is supplied without knives.

Light alloy body (Aluminum alloy). For cleaning do not use products containing caustic soda.

Esecuzione che permette di usare i differenti profili rappresentati in queste pagine.

L'articolo viene fornito senza coltelli.

Corpo in lega leggera (Lega di alluminio). Per la pulizia non utilizzare prodotti contenenti soda caustica.



D mm	B mm	d mm	Z	R	Max RPM 1/min.	Code Codice	SAP SAP
140	23	30	2		9.600	TD21M HA3	F03FC24421
140	23	32	2		9.600	TD21M HC3	F03FC24422
140	23	35	2		9.600	TD21M HB3	F03FC23145

Spare parts Parti di ricambio		Dimensions Dimensioni mm	Code Codice	SAP SAP
	Positioning plate / Piastra riscontro	33 x 3 x 16	VT18M AI9	F03FC20661
	Screw / Vite	M6 x 10	2622M CB9	F03FA07455
	Allen key / Chiave	4 x 110	CB03M BA9	F03FA00163
	Bushing / Bussola	35 x 20 x 30	BF01M AD9	F03FC00607

Profiled knives Coltelli profilati

Profile Profilo	Spare knives Coltelli di ricambio	Dimensions Dimensioni mm	Code Codice	SAP SAP
1	Knife / Coltello	41 x 22 x 3,5	CT21MAA302	F03FC24031
2	Knife / Coltello	41 x 22 x 3,5	CT21MBA302	F03FC24032
3	Knife / Coltello	41 x 22 x 3,5	CT21MCA302	F03FC24033
4	Knife / Coltello	41 x 22 x 3,5	CT21MDA302	F03FC24034
5	Knife / Coltello	41 x 22 x 3,5	CT21MEA302	F03FC24035

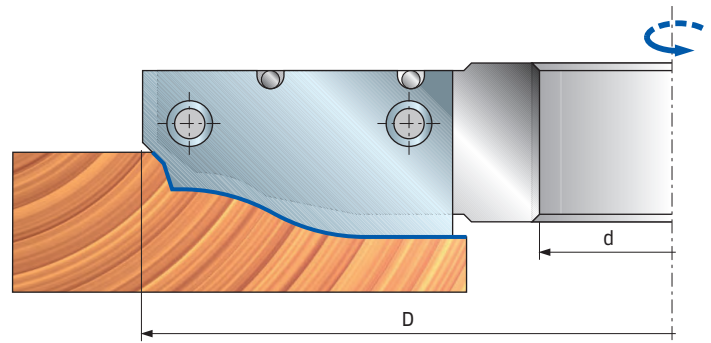
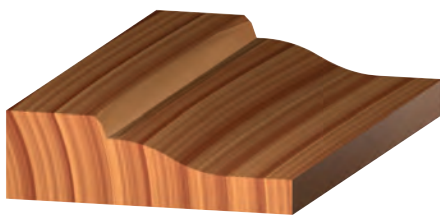

PROFILE / PROFILO 1

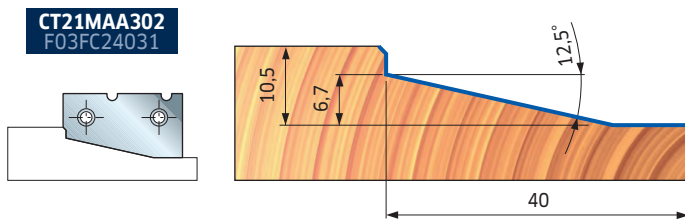

PROFILE / PROFILO 2

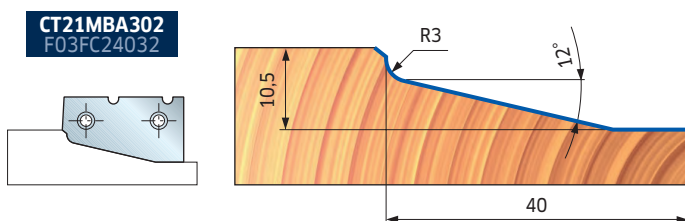
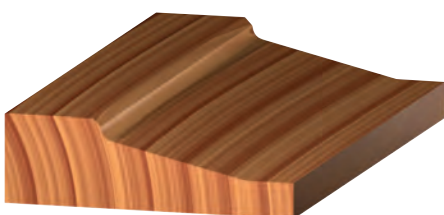

PROFILE / PROFILO 3

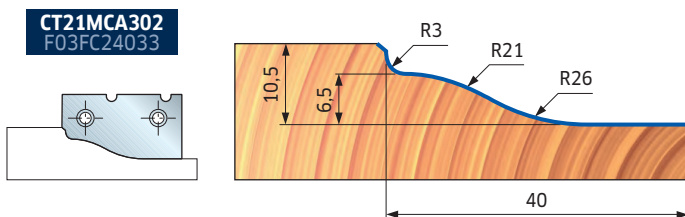
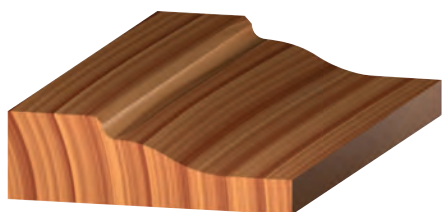

PROFILE / PROFILO 4

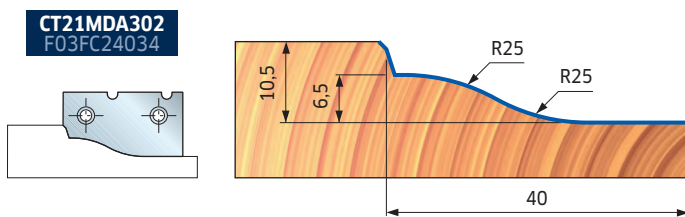
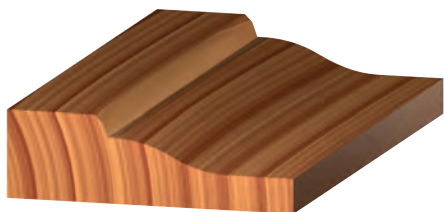

PROFILE / PROFILO 5

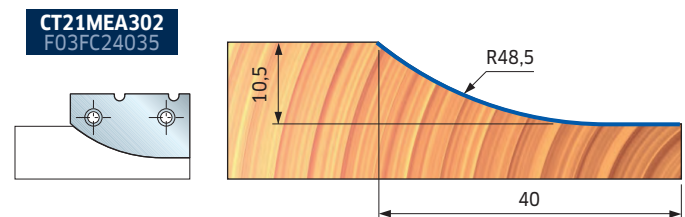
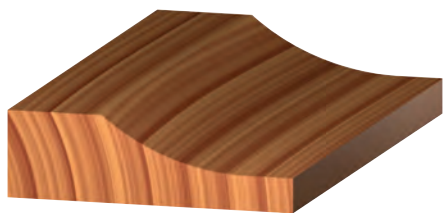

TD51M

Raised panel cutterheads for soft and hardwood Piattabande multiprofilo per legno tenero e duro

This tool is designed to perfectly cut softwood or hardwood with two knives, with both along the grain or end grain feeding. This result has been achieved by choosing different cutting angles according to the type of wood to be machined. Only two knives are to be fitted on the tool at one time, in opposite direction. The dimensions of the knives for cutting hardwood and softwood are different but the same profile is achieved.

This item is supplied without knives.

Light alloy body (Aluminum alloy). For cleaning do not use products containing caustic soda.

L'utensile è concepito per poter lavorare con 2 taglienti su legno tenero oppure con gli altri 2 taglienti su legno duro, con perfetta finitura, sia di testa che lungovena. Questo risultato si è potuto ottenere grazie alla scelta di diversi angoli di taglio sulle sedi per coltello. Si possono montare solo 2 coltelli alla volta e vanno montati diametralmente opposti. Le dimensioni dei coltelli per il legno duro sono diverse da quelle per legno tenero, però realizzano lo stesso profilo.

L'articolo viene fornito senza coltelli.

Corpo in lega leggera (Lega di alluminio). Per la pulizia non utilizzare prodotti contenenti soda caustica.



D mm	B mm	d* mm	Z	R	Max RPM 1/min.	Code Codice	SAP SAP
180	22	30	2+2		7.500	TD51M AA3	F03FC20209
180	22	32	2+2		7.500	TD51M AC3	F03FC24423
180	22	35 (50)	2+2		7.500	TD51M AB3	F03FC20210
180	21	50	2+2		7.500	TD51M AD3	F03FC20211

Spare parts Parti di ricambio		Dimensions Dimensioni mm	Code Codice	SAP SAP
	Ring / Rondella	14 x 2 x 6	VT18M AL9	F03FC20662
	Screw / Vite	M6 x 12	2622M CC9	F03FA07456
	Allen key / Chiave	4 x 130	CB03M BB9	F03FA00164

2 Knives for Softwood 2 Coltelli per Legno Tenero

	Profile Profilo	Dimensions Dimensioni mm	Code Codice	SAP SAP
	1	41 x 28 x 3,5	CT51MAA302	F03FC24036
	2	41 x 28 x 3,5	CT51MBA302	F03FC24037
	3	41 x 28 x 3,5	CT51MCA302	F03FC24038
	4	41 x 28 x 3,5	CT51MDA302	F03FC24039
	5	41 x 28 x 3,5	CT51MEA302	F03FC24040

2 Knives for Hardwood 2 Coltelli per Legno Duro

	Profile Profilo	Dimensions Dimensioni mm	Code Codice	SAP SAP
	1	41 x 22 x 3,5	CT21MAA302	F03FC24031
	2	41 x 22 x 3,5	CT21MBA302	F03FC24032
	3	41 x 22 x 3,5	CT21MCA302	F03FC24033
	4	41 x 22 x 3,5	CT21MDA302	F03FC24034
	5	41 x 22 x 3,5	CT21MEA302	F03FC24035

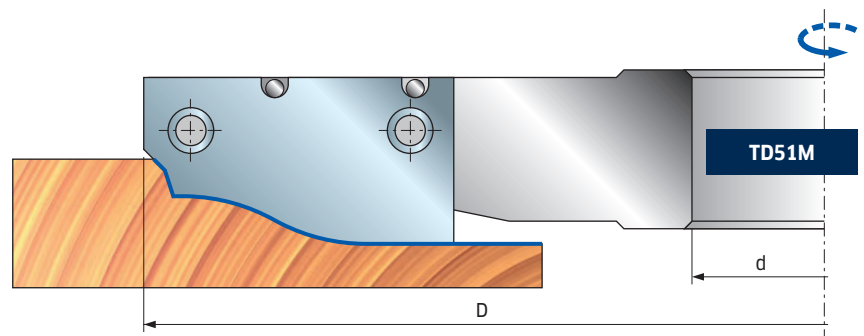
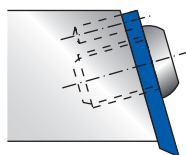
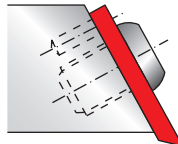

* Size shown between brackets is the max. rebore possible • La quota tra parentesi è la massima allargatura foro possibile

PROFILE / PROFILO 1

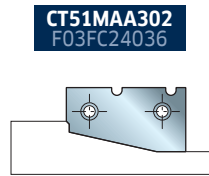

CT51MAA302
F03FC24036

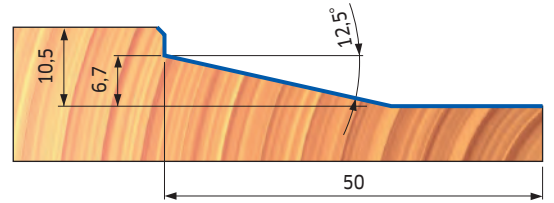

PROFILE / PROFILO 2

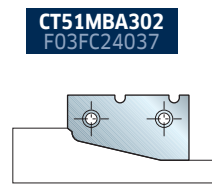
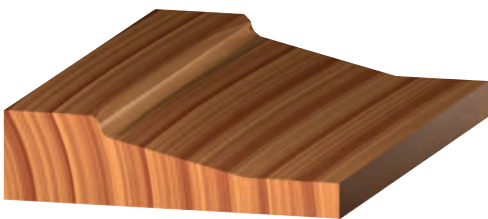

CT51MBA302
F03FC24037

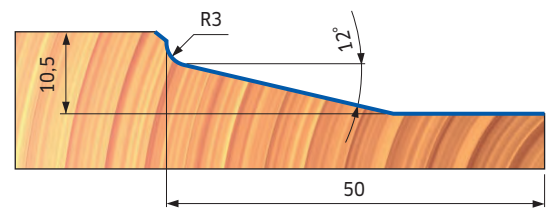

PROFILE / PROFILO 3

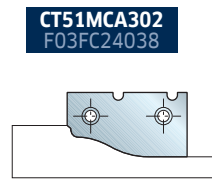
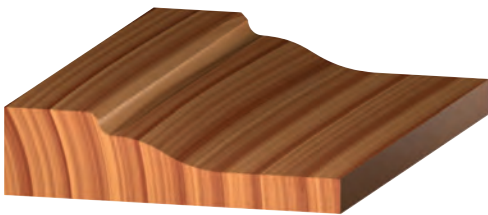

CT51MCA302
F03FC24038

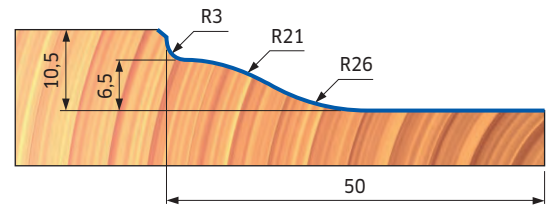

PROFILE / PROFILO 4

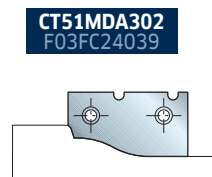
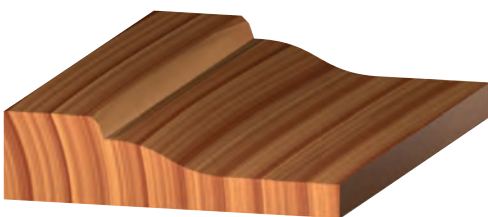

CT51MDA302
F03FC24039

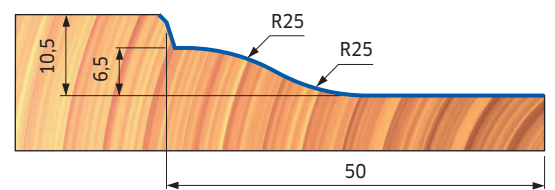

PROFILE / PROFILO 5

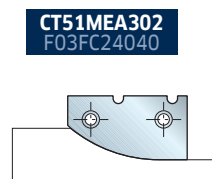

CT51MEA302
F03FC24040

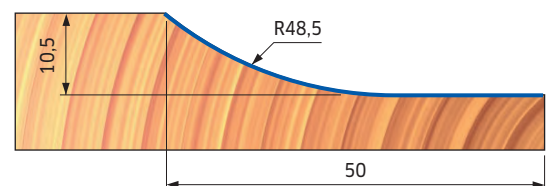

TD52M - TD52MD



Light alloy body (Aluminum alloy). For cleaning do not use products containing caustic soda.

Corpo in lega leggera (Lega di alluminio). Per la pulizia non utilizzare prodotti contenenti soda caustica.

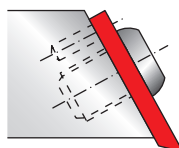
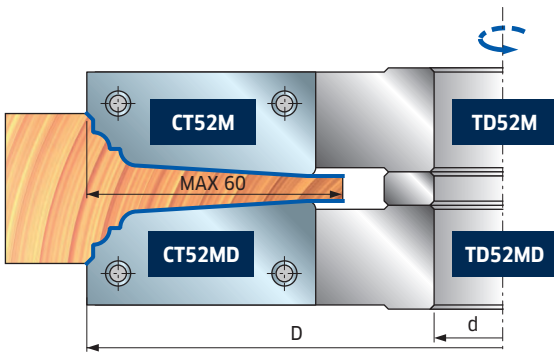

Knife Coltello	Profile Profilo	Dimensions Dimensioni mm	Code Codice	SAP SAP
1		55 x 30 x 3,5	CT52MTA301	F03FC24056
			CT52MDTA301	F03FC24051
2		55 x 30 x 3,5	CT52MTB301	F03FC24057
			CT52MDTB301	F03FC24052
3		55 x 30 x 3,5	CT52MTC301	F03FC24058
			CT52MDTC301	F03FC24053
4		55 x 30 x 3,5	CT52MTD301	F03FC24059
			CT52MDTD301	F03FC24054
5		55 x 30 x 3,5	CT52MTE301	F03FC24060
			CT52MDTE301	F03FC24055

2 Knives for Hardwood - 2 Coltelli per Legno Duro

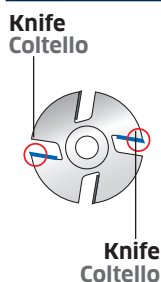
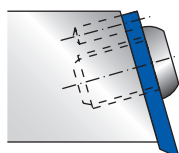

Knife Coltello	Profile Profilo	Dimensions Dimensioni mm	Code Codice	SAP SAP
1		55 x 25 x 3,5	CT52MDA301	F03FC24041
			CT52MDDA301	F03FC24044
2		55 x 25 x 3,5	CT52MDB301	F03FC24042
			CT52MDBB301	F03FC24045
3		55 x 25 x 3,5	CT52MDC301	F03FC24043
			CT52MDCC301	F03FC24046
4		55 x 25 x 3,5	CT52MDD301	F03FC24049
			CT52MDDD301	F03FC24047
5		55 x 25 x 3,5	CT52MDE301	F03FC24050
			CT52MDDE301	F03FC24048

Raised panel cutterheads for soft and hardwood Piattabande multiprofilo per legno tenero e duro

This tool is designed to perfectly cut softwood or hardwood with two knives, with both along the grain or end grain feeding. This result has been achieved by choosing different cutting angles according to the type of wood to be machined. Only two knives are to be fitted on the tool at one time, in the opposite direction. The dimensions of the knives for cutting hardwood and softwood are different but the same profile is achieved.

L'utensile è concepito per poter lavorare con 2 taglienti su legno tenero oppure con gli altri 2 taglienti su legno duro, con perfetta finitura, sia di testa che lungovena. Questo risultato si è potuto ottenere grazie alla scelta di diversi angoli di taglio sulle sedi per coltello. Si possono montare solo 2 coltelli alla volta e vanno montati diametralmente opposti. Le dimensioni dei coltelli per il legno duro sono diverse da quelle per legno tenero, però realizzano lo stesso profilo.

Items are supplied with knives - Articoli forniti con coltelli

D mm	B mm	d* mm	Z	Max RPM 1/min.	Code Codice	SAP SAP
200	25	30	2+2	7.000	TD52M CA3	F03FC24424
200	25	30	2+2	7.000	TD52MD CA3	F03FC24426
200	25	32	2+2	7.000	TD52M CC3	F03FC24425
200	25	32	2+2	7.000	TD52MD CC3	F03FC24427
200	25	35 (50)	2+2	7.000	TD52M CB3	F03FC20212
200	25	35 (50)	2+2	7.000	TD52MD CB3	F03FC20214

Items are supplied without knives - Articoli forniti senza coltelli

D mm	B mm	d* mm	Z	Max RPM 1/min.	Code Codice	SAP SAP
200	25	30	2+2	7.000	TD52M HA3	F03F668623
200	25	30	2+2	7.000	TD52MD HA3	F03F668625
200	25	32	2+2	7.000	TD52M HC3	F03F668624
200	25	32	2+2	7.000	TD52MD HC3	F03F668626
200	25	35 (50)	2+2	7.000	TD52M HB3	F03FC20213
200	25	35 (50)	2+2	7.000	TD52MD HB3	F03FC20215

Spare parts Parti di ricambio	Dimensions Dimensioni mm	Code Codice	SAP SAP
Ring / Rondella	14 x 2 x 6	VT18M AL9	F03FC20662
Screw / Vite	M6 x 12	2622M CC9	F03FA07456
Allen key / Chiave	4 x 130	CB03M BB9	F03FA00164

2 Knives for Softwood - 2 Coltelli per Legno Tenero

Knife Coltello	Profile Profilo	Dimensions Dimensioni mm	Code Codice	SAP SAP
1		55 x 30 x 3,5	CT52MTA301	F03FC24056
			CT52MDTA301	F03FC24051
2		55 x 30 x 3,5	CT52MTB301	F03FC24057
			CT52MDTB301	F03FC24052
3		55 x 30 x 3,5	CT52MTC301	F03FC24058
			CT52MDTC301	F03FC24053
4		55 x 30 x 3,5	CT52MTD301	F03FC24059
			CT52MDTD301	F03FC24054
5		55 x 30 x 3,5	CT52MTE301	F03FC24060
			CT52MDTE301	F03FC24055

PROFILE / PROFILO 1

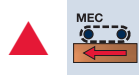
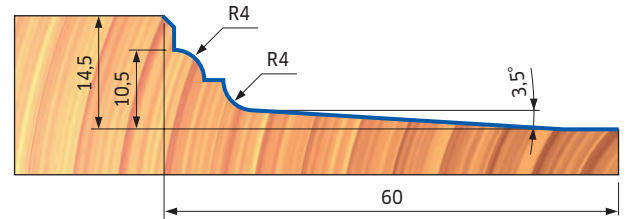
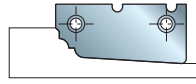
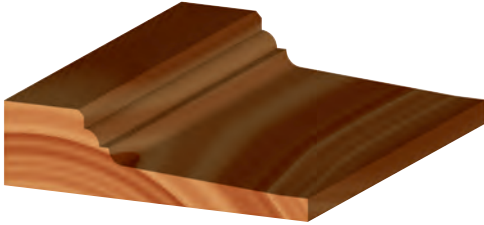

This profile is usable with automatic feed only.
Questo profilo è utilizzabile solamente con avanzamento meccanico.

PROFILE / PROFILO 2

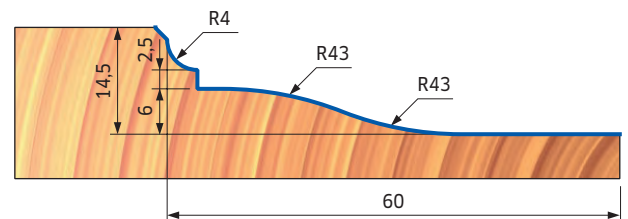
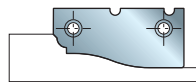
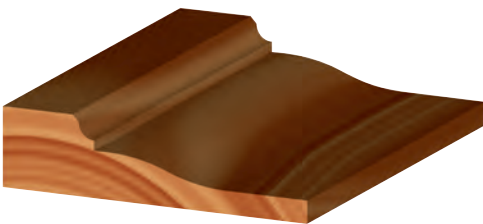

PROFILE / PROFILO 3

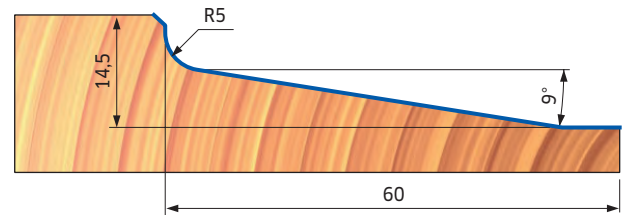
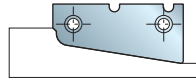
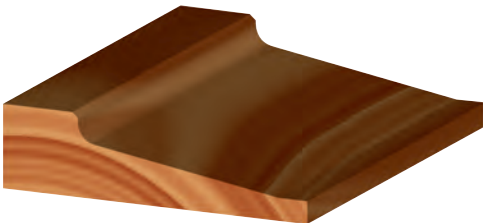

PROFILE / PROFILO 4

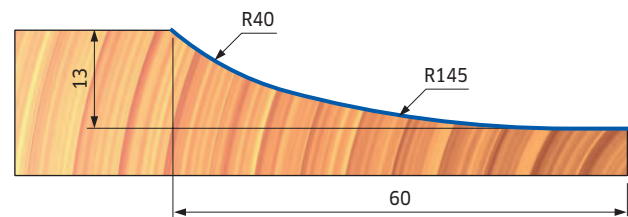
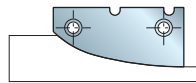
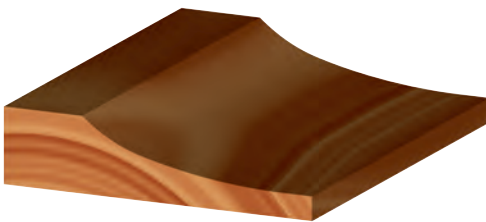

PROFILE / PROFILO 5

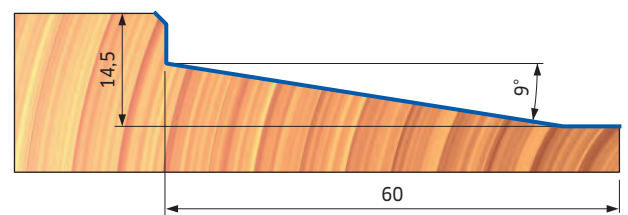
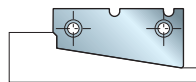
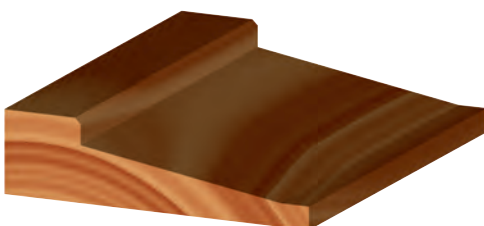

TD55MD - TD55MS

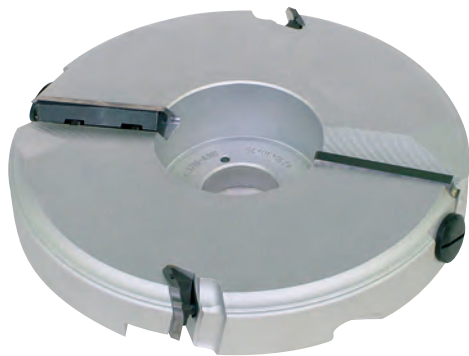

It is possible to fit 5 types of standard knives for machining 5 different profiles (see drawings). Due to the particular tool geometry, this item is particularly indicated for cutting deep profiles.

These items are supplied without knives.

Light alloy body (Aluminum alloy). For cleaning do not use products containing caustic soda.

Con questo utensile si possono ottenere n. 5 tipi di profili diversi (vedi disegni). Possibilità di realizzare specchietti lunghi anche oltre l'albero portautensili (particolarmente utile per l'esecuzione di specchietti per portoni).

Questi articoli vengono forniti senza coltelli.

Corpo in lega leggera (Lega di alluminio). Per la pulizia non utilizzare prodotti contenenti soda caustica.

Raised panel cutterheads Piattabande multiprofilo

D mm	B mm	d* mm	Z	R	Max RPM 1/min.	Code Codice	SAP SAP
210		30	2+2		6.500	TD55MD BA3	F03F668627
210		32	2+2		6.500	TD55MD BC3	F03F668628
210		35 (50)	2+2		6.500	TD55MD BB3	F03FC20217
210		30	2+2		6.500	TD55MS BA3	F03F668629
210		32	2+2		6.500	TD55MS BC3	F03F668630
210		35 (50)	2+2		6.500	TD55MS BB3	F03FC20219

Spare parts Parti di ricambio		Dimensions Dimensioni mm	Code Codice	SAP SAP	
	Screw / Vite	M10 x 25	2602M F19	F03FA07353	
	Screw / Vite	M8 x 10 x 22	VT08M AD9	F03FA04456	
	Screw / Vite	M5 x 7 x 16	VT08M AE9	F03FA04457	
	Allen key / Chiave	5 x 110	CB03M EC9	F03FA00171	
TD55MS TD55MD		Wedge / Cuneo A	21 x 23 x 8	CN55MD AA9A	F03FC24544
		Wedge / Cuneo B	61 x 18 x 8	CN55MD BA9	F03FC01441
		Wedge / Cuneo A	21 x 23 x 8	CN55MS AA9A	F03FC24545
		Wedge / Cuneo B	61 x 18 x 8	CN55MS BA9	F03FC01443

Knives for TD55MD - Coltelli per TD55MD

Profile Profilo	Spare knives Coltelli di ricambio	Dimensions Dimensioni mm	Code Codice	SAP SAP
1	Knife / Coltello A	23 x 24 x 3	CT55MDAA301	F03FC24078
	Knife / Coltello B	65 x 20 x 3	CT55MDBA301	F03FC24087
2	Knife / Coltello A	23 x 24 x 3	CT55MDAB301	F03FC24079
	Knife / Coltello B	65 x 20 x 3	CT55MDBB301	F03FC24088
3	Knife / Coltello A	23 x 24 x 3	CT55MDAC301	F03FC24080
	Knife / Coltello B	65 x 20 x 3	CT55MDBC301	F03FC24089
4	Knife / Coltello A	23 x 24 x 3	CT55MDAE301	F03FC24082
	Knife / Coltello B	65 x 20 x 3	CT55MDBE301	F03FC24091
5	Knife / Coltello A	23 x 24 x 3	CT55MDAF301	F03FC24083
	Knife / Coltello B	65 x 20 x 3	CT55MDBF301	F03FC24092

Knives for TD55MS - Coltelli per TD55MS

Profile Profilo	Spare knives Coltelli di ricambio	Dimensions Dimensioni mm	Code Codice	SAP SAP
1	Knife / Coltello A	23 x 24 x 3	CT55MSAA301	F03FC24096
	Knife / Coltello B	65 x 20 x 3	CT55MSBA301	F03FC24105
2	Knife / Coltello A	23 x 24 x 3	CT55MSAB301	F03FC24097
	Knife / Coltello B	65 x 20 x 3	CT55MSBB301	F03FC24106
3	Knife / Coltello A	23 x 24 x 3	CT55MSAC301	F03FC24098
	Knife / Coltello B	65 x 20 x 3	CT55MSBC301	F03FC24107
4	Knife / Coltello A	23 x 24 x 3	CT55MSAE301	F03FC24100
	Knife / Coltello B	65 x 20 x 3	CT55MSBE301	F03FC24109
5	Knife / Coltello A	23 x 24 x 3	CT55MSAF301	F03FC24101
	Knife / Coltello B	65 x 20 x 3	CT55MSBF301	F03FC24110

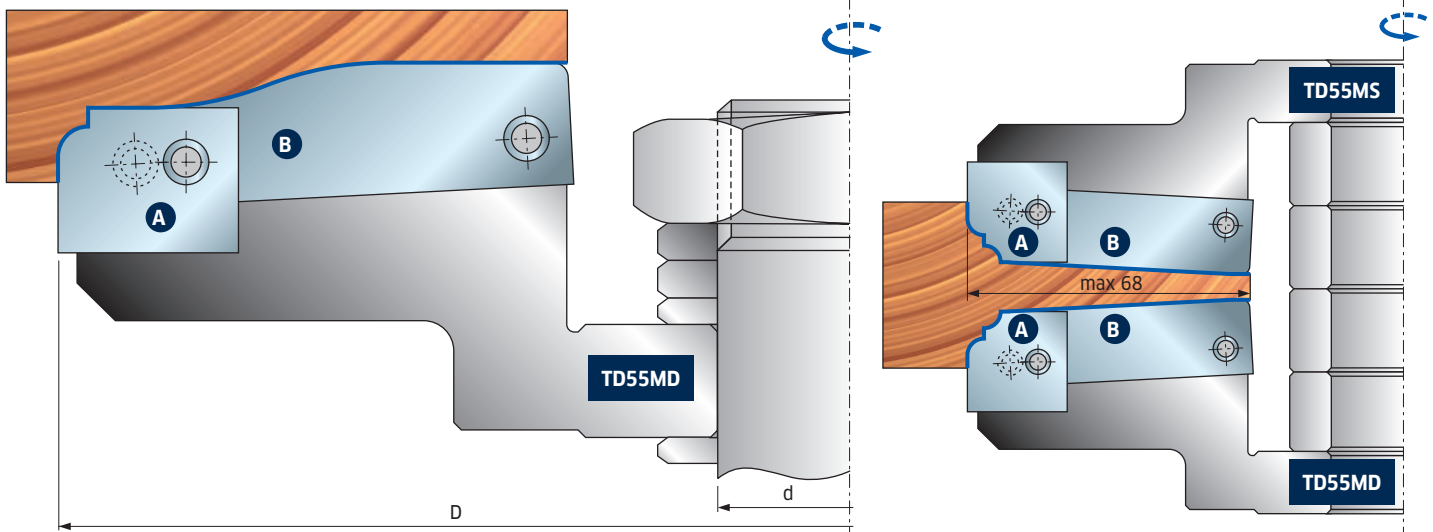

PROFILE / PROFILO 1

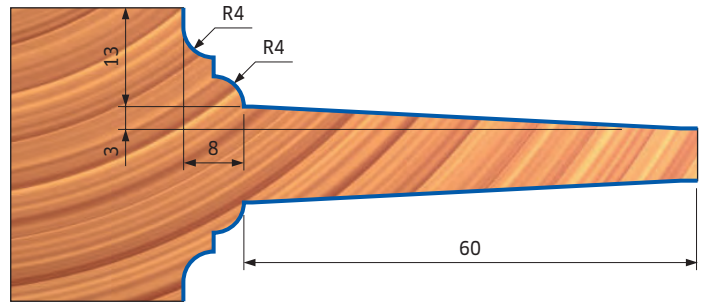
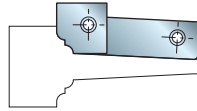
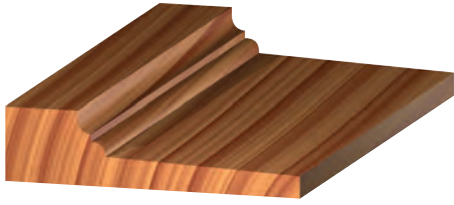

PROFILE / PROFILO 2

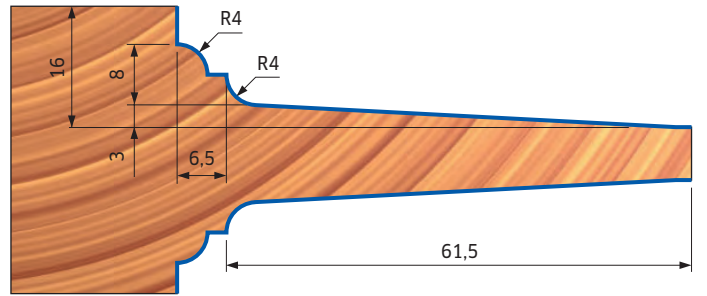
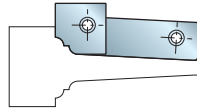

PROFILE / PROFILO 3

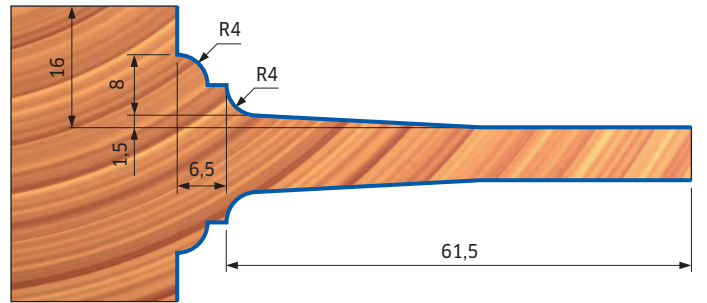
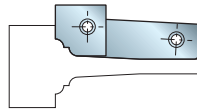

PROFILE / PROFILO 4

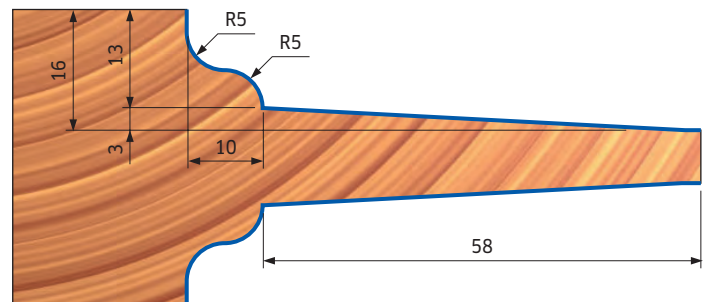
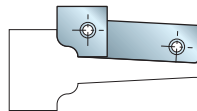

PROFILE / PROFILO 5

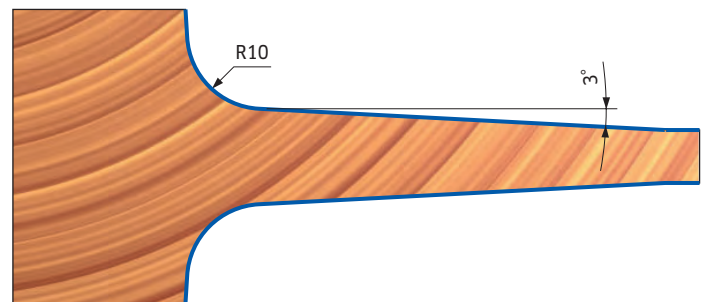
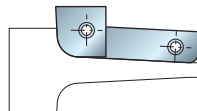
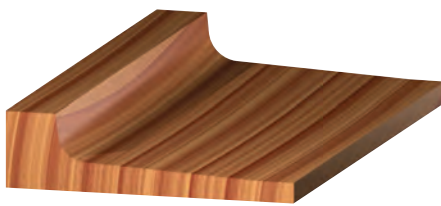

This profile is usable with automatic feed only.
Questo profilo è utilizzabile solamente con avanzamento meccanico.

TD55MD - TD55MS



Is possible to fit 4 types of standard knives for machining 4 different profiles (see drawings). Due to the particular tool geometry, this item is particularly indicated for cutting deep profiles.

These items are supplied without knives.

Light alloy body (Aluminum alloy). For cleaning do not use products containing caustic soda.

Con questo utensile si possono ottenere n. 4 tipi di profili diversi (vedi disegni). Possibilità di realizzare specchietti lunghi anche oltre l'albero portautensili (particolarmente utile per l'esecuzione di specchietti per portoni).

Questi articoli vengono forniti senza coltelli.

Corpo in lega leggera (Lega di alluminio). Per la pulizia non utilizzare prodotti contenenti soda caustica.

Raised panel cutterheads Piattabande multiprofilo

D mm	B mm	d* mm	Z	R	Max RPM 1/min.	Code Codice	SAP SAP
210		30	2+2		6.500	TD55MD CA3	F03F668934
210		32	2+2		6.500	TD55MD CC3	F03F668935
210		35 (50)	2+2		6.500	TD55MD CB3	F03FC20218
210		30	2+2		6.500	TD55MS CA3	F03F668936
210		32	2+2		6.500	TD55MS CC3	F03F668937
210		35 (50)	2+2		6.500	TD55MS CB3	F03FC20220

Spare parts Parti di ricambio		Dimensions Dimensioni mm	Code Codice	SAP SAP
	Vite / Screw	M10 x 25	2602M FI9	F03FA07353
	Vite / Screw	M8 x 10 x 22	VT08M AD9	F03FA04456
	Vite / Screw	M5 x 7 x 16	VT08M AE9	F03FA04457
	Chiave / Allen key	5 x 110	CB03M EC9	F03FA00171
TD55MS TD55MD	Wedge / Cuneo A	21 x 23 x 8	CN55MD AA9A	F03FC24544
	Wedge / Cuneo B	61 x 18 x 8	CN55MD BA9	F03FC01441
	Wedge / Cuneo A	21 x 23 x 8	CN55MS AA9A	F03FC24545
	Wedge / Cuneo B	61 x 18 x 8	CN55MS BA9	F03FC01443

Knives for TD55MD - Coltelli per TD55MD

Profile Profilo	Spare knives Coltelli di ricambio	Dimensions Dimensioni mm	Code Codice	SAP SAP
1	Knife / Coltello A	20 x 24 x 3	CT55MDAD301	F03FC24081
	Knife / Coltello B	65 x 20 x 3	CT55MDBD301	F03FC24090
2	Knife / Coltello A	20 x 24 x 3	CT55MDAG301	F03FC24084
	Knife / Coltello B	65 x 20 x 3	CT55MDBG301	F03FC24093
3	Knife / Coltello A	20 x 24 x 3	CT55MDAH301	F03FC24085
	Knife / Coltello B	65 x 20 x 3	CT55MDBH301	F03FC24094
4	Knife / Coltello A	20 x 24 x 3	CT55MDAI301	F03FC24086
	Knife / Coltello B	65 x 20 x 3	CT55MDBI301	F03FC24095

Knives for TD55MS - Coltelli per TD55MS

Profile Profilo	Spare knives Coltelli di ricambio	Dimensions Dimensioni mm	Code Codice	SAP SAP
1	Knife / Coltello A	20 x 24 x 3	CT55MSAD301	F03FC24099
	Knife / Coltello B	65 x 20 x 3	CT55MSBD301	F03FC24108
2	Knife / Coltello A	20 x 24 x 3	CT55MSAG301	F03FC24102
	Knife / Coltello B	65 x 20 x 3	CT55MSBG301	F03FC24111
3	Knife / Coltello A	20 x 24 x 3	CT55MSAH301	F03FC24103
	Knife / Coltello B	65 x 20 x 3	CT55MSBH301	F03FC24112
4	Knife / Coltello A	20 x 24 x 3	CT55MSAI301	F03FC24104
	Knife / Coltello B	65 x 20 x 3	CT55MSBI301	F03FC24113

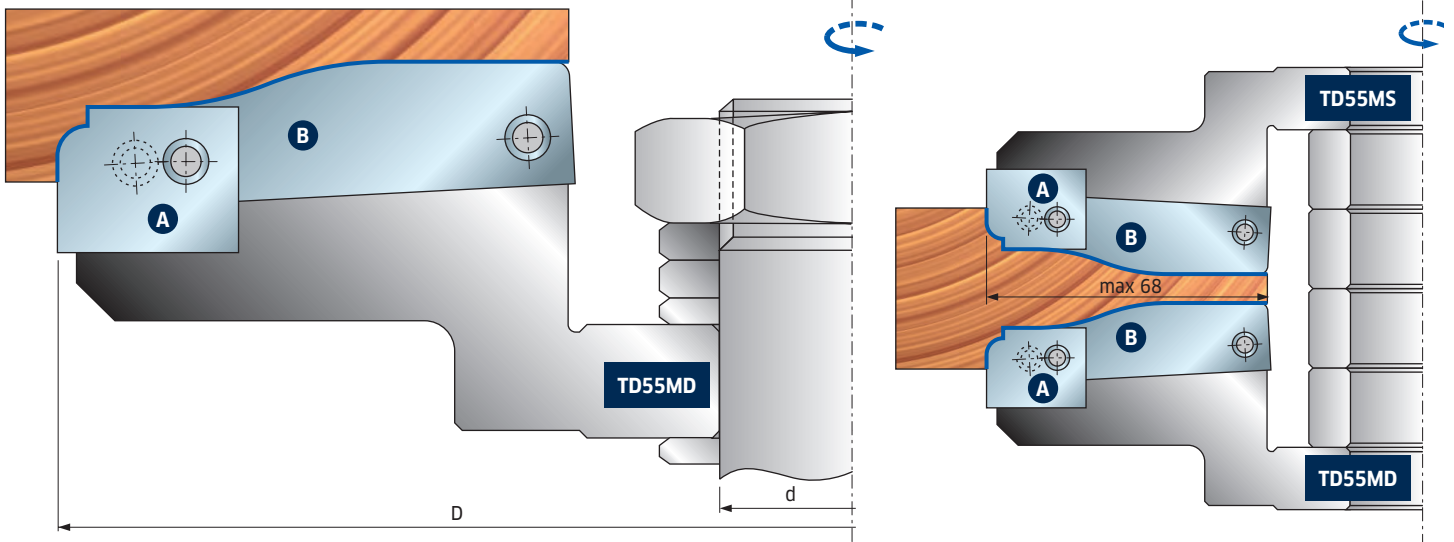

PROFILE / PROFILO 1

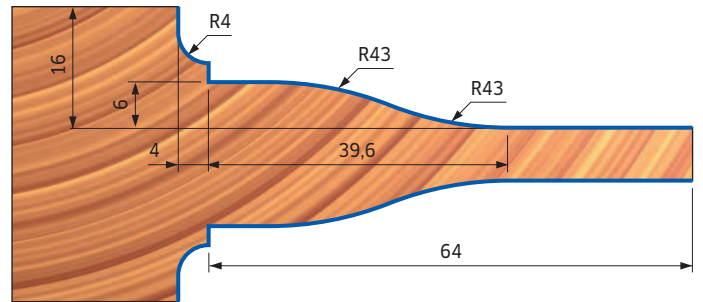
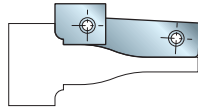
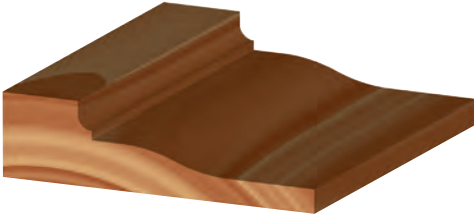

PROFILE / PROFILO 2

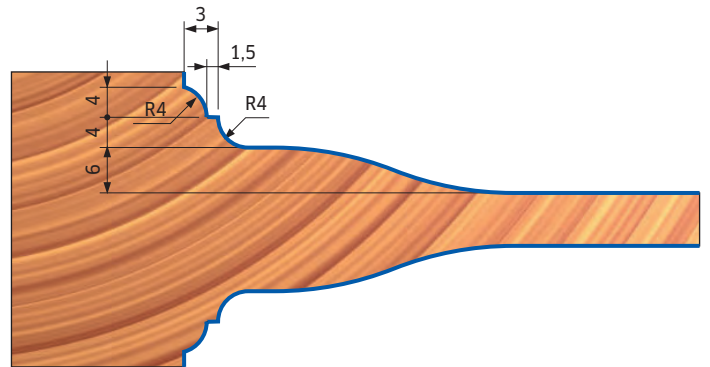
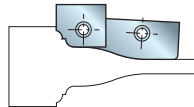
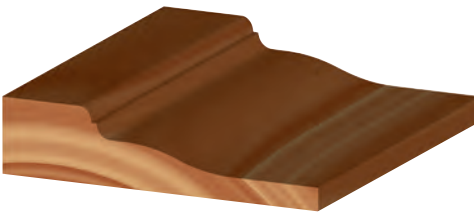

PROFILE / PROFILO 3

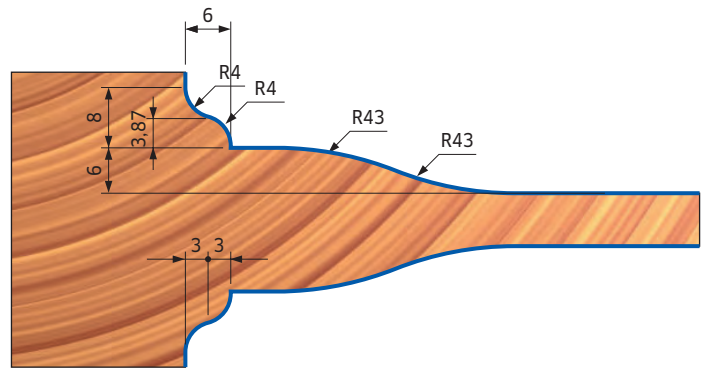
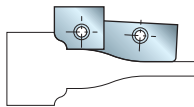
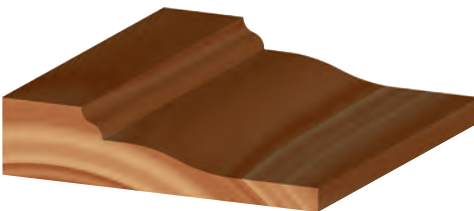

PROFILE / PROFILO 4

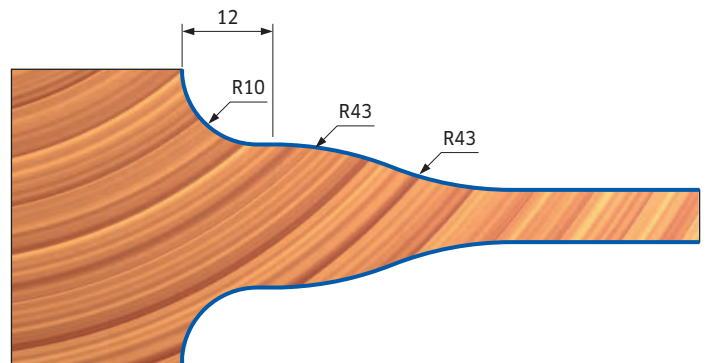
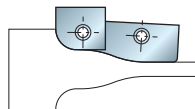
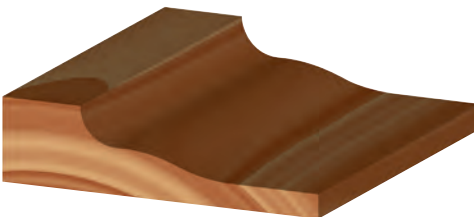

freud.

freud S.p.A.
Società Unipersonale
Via Padova, 3
33010 Tavagnacco (UD) IT
Tél. +39 0432 551411
Fax +39 0432 551440
info@freud.it
www.freud.it

DISTRIBUTER ZA SRBIJU

GATECH

DUČEVAC 15 - 11260 UMKA - SRBIJA

☎ 011/802-70-70 ✉ info@gatech.rs

www.gatech.rs