

freud.

**Cutterheads and
Brazen Cutters
Teste Portacoltelli e Frese
Saldobrasate**

Catalogue - Catalogo

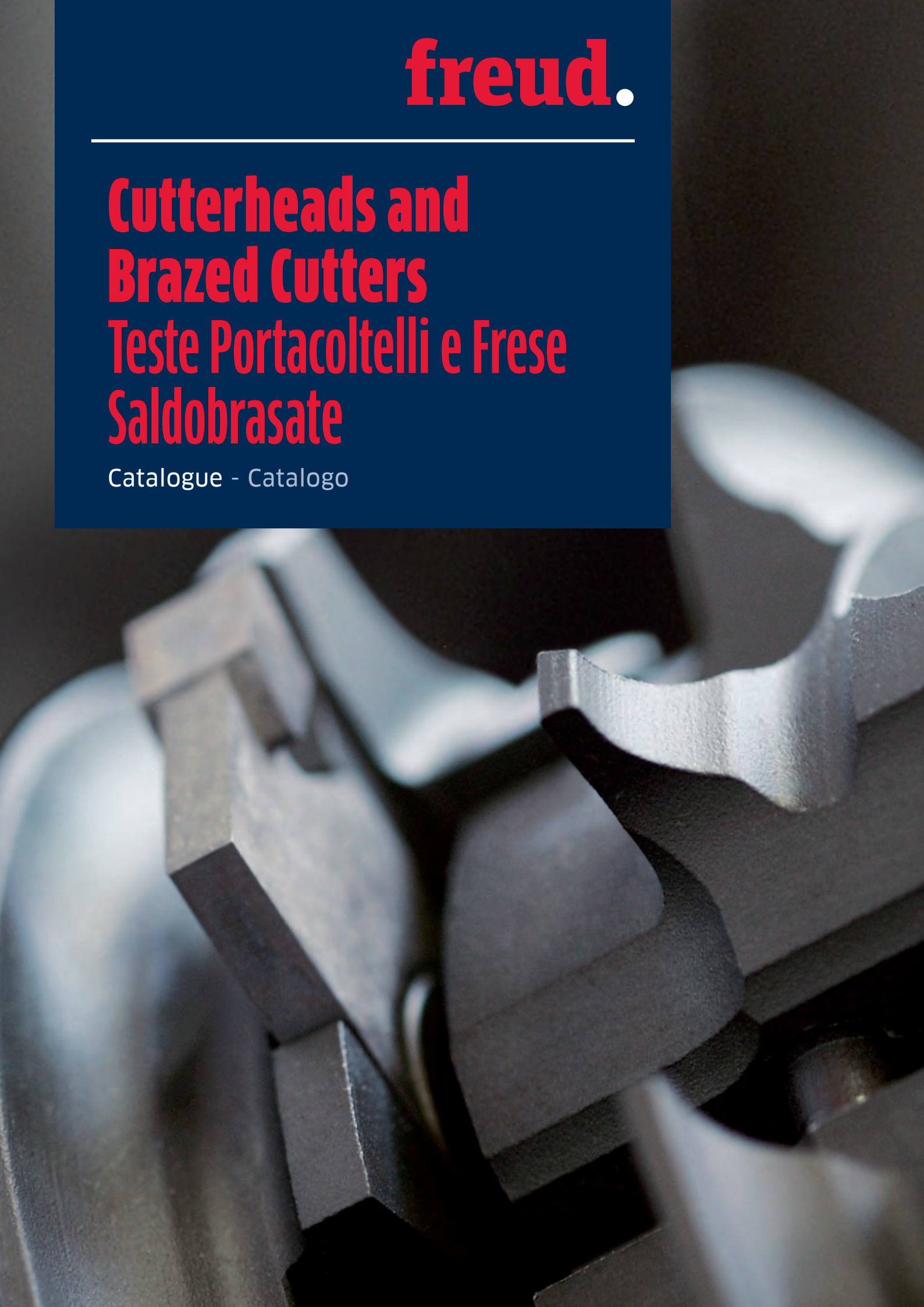

T111M - T112M

Z = 4

Z = 4+4

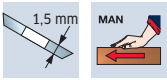

Cutterheads for rebates

Teste per battute

Can be used on CNC machines.

Rebore not available.

Light alloy body (Aluminum alloy). For cleaning do not use products containing caustic soda.

Utilizzabile su pantografo.

Non è consentita l'allargatura del foro.

Corpo in lega leggera (Lega di alluminio). Per la pulizia non utilizzare prodotti contenenti soda caustica.

D mm	B mm	d mm	Z	R	Max RPM 1/min.	Code Codice	SAP SAP
85	50	30	4		12.000	T111M BA3	F03FC20578
85	50	30	4	4	12.000	T112M BA3	F03FC20579

Spare parts Parti di ricambio		Dimensions Dimensioni mm	Code Codice	SAP SAP
	Knife / Coltello	50 x 12 x 1,5	CG01MFA310	F03FH02851
	Screw / Vite	M8 x 16	VT03M AA9	F03FA04435
	Wedge / Cuneo	46	CN01M KA9	F03FC01255
	Allen key / Chiave a "L"	4	2619M EA9	F03FA07434
	Torx key / Chiave Torx	T20	CB03M CC9	F03FA00167
T111M	Spur / Rasante	14 x 14 x 2	RG01MAA310	F03FH03034
	Screw / Vite	M5 x 8	VT05M AA9	F03FA04444

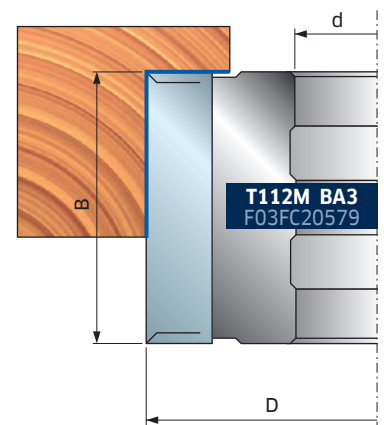
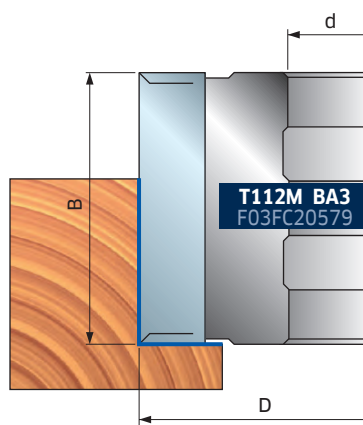
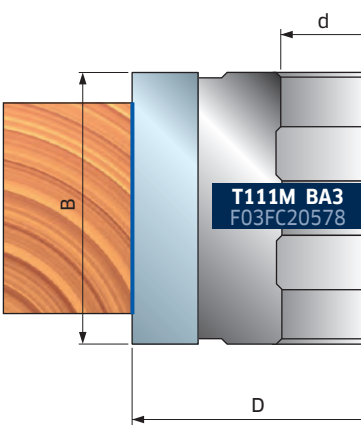
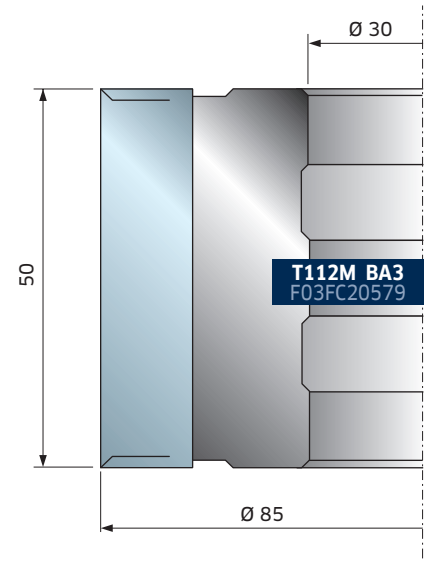
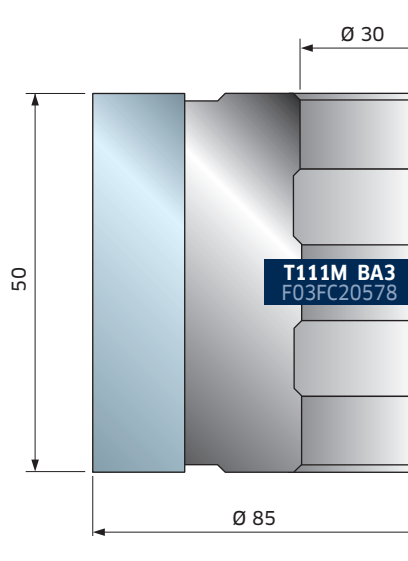
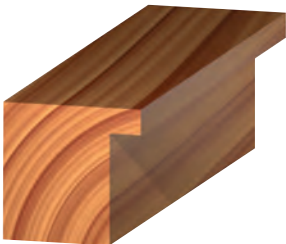
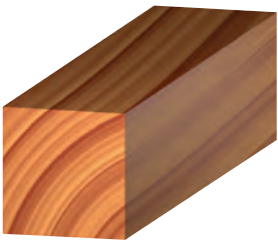

T191M - T192M

Z = 4







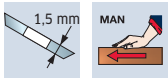

Z = 2

Cutterheads for rebates Teste per battute

Tools with alternate shear angle.
Utensili con angolo assiale alterno.



D mm	B mm	d* mm	Z	R	Max RPM 1/min.	Code Codice	SAP SAP
125	50	30 (50)	4	4	10.600	T191M BA3	F03FC20600
125	50	35 (50)	4	4	10.300	T191M BB3	F03FC20601
125	50	40 (50)	4	4	10.300	T191M BC3	F03FC20602
125	50	50	4	4	10.600	T191M BD3	F03FC20603
125	50	40 (50)	2	4	10.600	T192M BC3	F03FC20605

Spare parts Parti di ricambio	Dimensions Dimensioni mm	Code Codice	SAP SAP
	Knife / Coltello 50 x 12 x 1,5	CG01MFA310	F03FH02851
	Wedge / Cuneo 15 x 46 x 8	CN09M AP9	F03FC01290
	Screw / Vite M10 x 22	VT19M MA9	F03FA04496
	Screw / Vite M5 x 8	VT05M AA9	F03FA04444
	Nut / Ogiva 15 x 13,3 x 10	VT20M MA9	F03FC20670
	Spur / Rasante 14 x 14 x 2	RG01MAA310	F03FH03034
	Allen key / Chiave 5 x 110	CB03M EA9	F03FA00169
	Torx key / Chiave Torx T20	CB03M CC9	F03FA00167

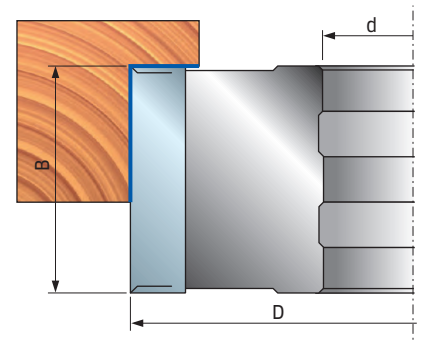
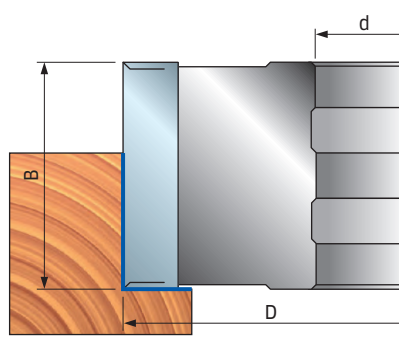
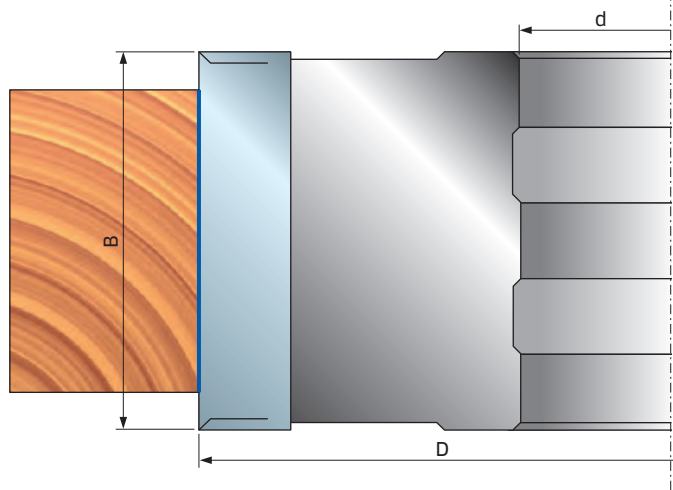
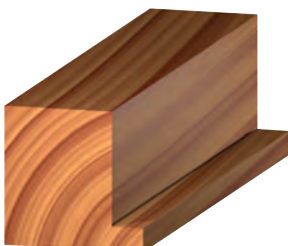
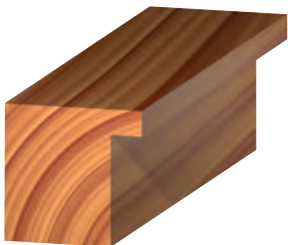

* Size shown between brackets is the max. rebore possible • La quota tra parentesi è la massima allargatura foro possibile

T193M

Cutterheads for rebates Teste per battute

Tools with alternate shear angle.

Light alloy body (Aluminum alloy). For cleaning do not use products containing caustic soda.

Utensili con angolo assiale alterno.

Corpo in lega leggera (Legga di alluminio). Per la pulizia non utilizzare prodotti contenenti soda caustica.

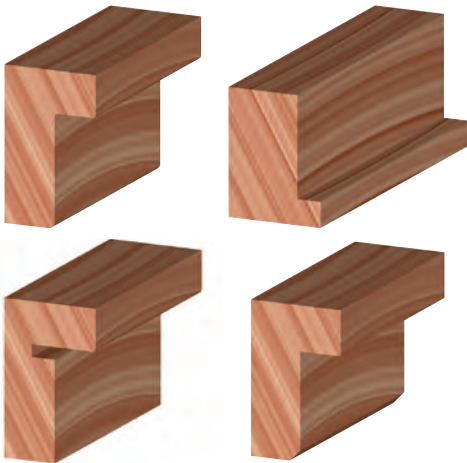
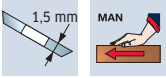

D mm	B mm	d* mm	Z	R	Max RPM 1/min.	Code Codice	SAP SAP
125	50	32	4	2	10.300	T193M BC3	F03F668306
125	50	30 (50)	4	2	10.300	T193M BA3	F03FC20606

Spare parts Parti di ricambio	Dimensions Dimensioni mm	Code Codice	SAP SAP
	Knife / Coltello 50 x 12 x 1,5	CG01MFA310	F03FH02851
	Wedge / Cuneo 15 x 46 x 8	CN09M AP9	F03FC01290
	Nut / Ogiva 15 x 13,3 x 10	VT20M MA9	F03FC20670
	Screw / Vite M10 x 22	VT19M MA9	F03FA04496
	Spur / Rasante 14 x 14 x 2	RG01MAA310	F03FH03034
	Screw / Vite M5 x 8	VT05M AA9	F03FA04444
	Adjustment ring / Rondella di reg. 16 x 11,9 x 2,6	VT18M AG9	F03FC20660
	Screw / Vite M6 x 10	2622M CB9	F03FA07455
	Allen key / Chiave 5 x 110	CB03M EA9	F03FA00169
	Allen key / Chiave 4 x 110	CB03M BA9	F03FA00163
	Torx key / Chiave Torx T20	CB03M CC9	F03FA00167

Tool with seat pockets for the following inserts (not included):

Utensile con sedi per il montaggio dei seguenti inserti (non inclusi):

Inserts Inserti	Screw type and dimensions Tipo e dimensioni viti	Code screws Codice viti	SAP SAP	Pcs Pz.
IG25M	M6 x 10	2622M CB9	F03FA07455	2
IG61M-IG62M-IG51M-IG52M	M6 x 14,5	VT16M AA9	F03FA04476	2
IG33M	M6 x 18,5	VT16M AC9	F03FC20656	2
SR11MD	M5 x 8	VT05M AA9	F03FA04444	4

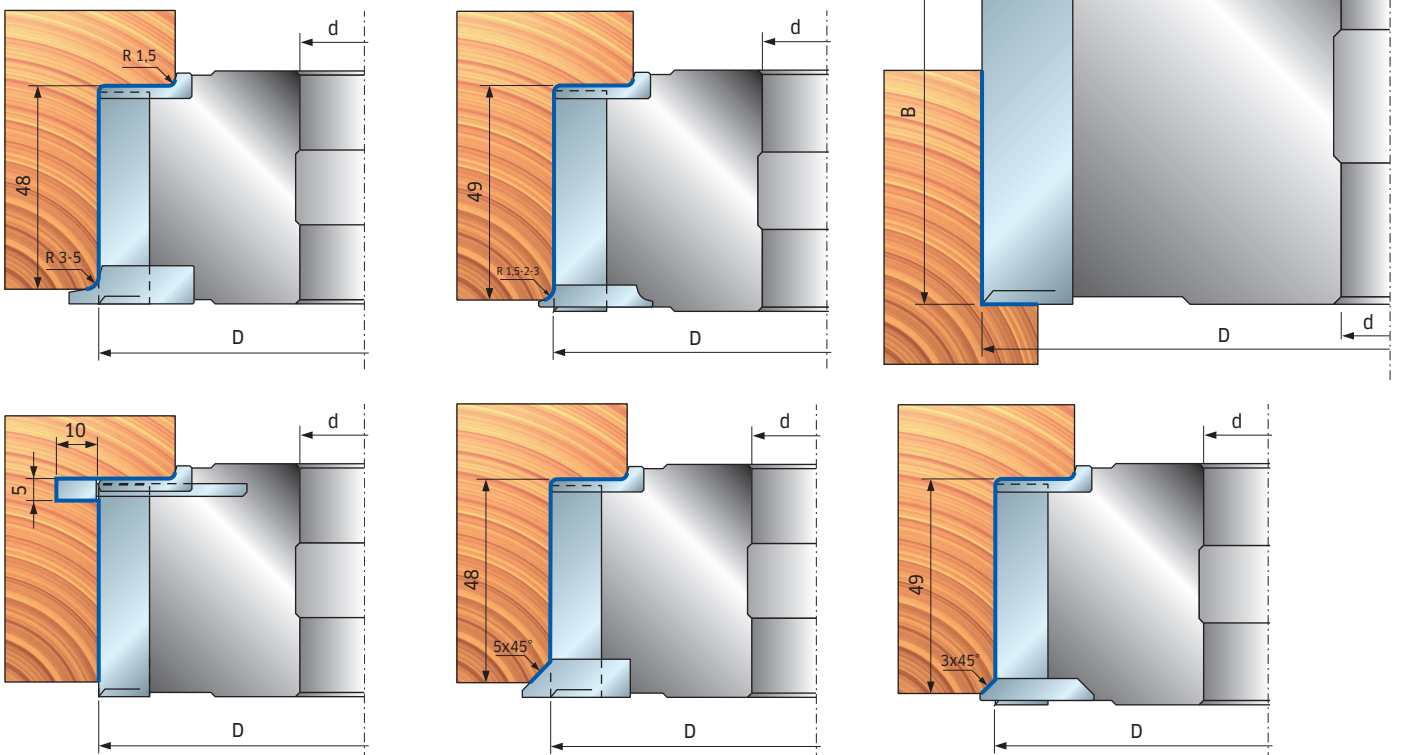

* Size shown between brackets is the max. rebore possible • La quota tra parentesi è la massima allargatura foro possibile

T194M - T195M

Z = 4

Z = 2

Cutterheads for rebates Teste per battute

Tools with alternate shear angle.

With seat pockets for bevelling inserts (not included):

IG61MS or radius inserts IG62MS (R= 1,5 - 2 - 3 mm) for T194M

IG01M BA3 or radius inserts IG02M (R= 1 - 1,5 - 2 - 3 mm) for T195M.

Light alloy body (Aluminum alloy). For cleaning do not use products containing caustic soda.

Utensili con angolo assiale alterno.

Con sedi per il montaggio dei seguenti inserti (non inclusi):

IG61MS (smussatori) e IG62MS (R= 1,5 - 2 - 3 mm) per T194M

IG01M BA3 (smussatore) e IG02M (R= 1 - 1,5 - 2 - 3 mm) per T195M.

Corpo in lega leggera (Lega di alluminio). Per la pulizia non utilizzare prodotti contenenti soda caustica.

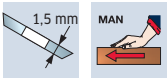
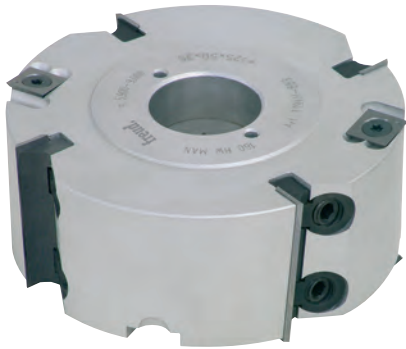

D mm	B mm	d* mm	Z	R	Max RPM 1/min.	Code Codice	SAP SAP
125	30	32	4	4	10.300	T194M AC3	F03F668307
125	50	32	4	4	10.300	T194M BC3	F03F668308
125	30	35 (50)	4	4	10.300	T194M AB3	F03FC20607
125	50	35 (50)	4	4	10.300	T194M BB3	F03FC20608
125	50	35 (50)	2	4	10.300	T195M BB3	F03FC20610

Spare parts Parti di ricambio		Dimensions Dimensioni mm	Code Codice	SAP SAP	
	Spur / Rasante	14 x 14 x 2	RG01MAA310	F03FH03034	
	Screw / Vite	M5 x 8	VT05M AA9	F03FA04444	
	Screw / Vite	M10 x 22	VT19M MA9	F03FA04496	
	Screw / Vite	M6 x 14,5	VT16M AA9	F03FA04476	
	Nut / Ogiva	15 x 13,3 x 10	VT20M MA9	F03FC20670	
	Allen key / Chiave	5 x 110	CB03M EA9	F03FA00169	
	Torx key / Chiave Torx	T20	CB03M CC9	F03FA00167	
AB3 BC3 AC3		Knife / Coltello	30 x 12 x 1,5	CG01MEA310	F03FH02737
		Wedge / Cuneo	15 x 26 x 8	CN09M AD9	F03FC01283
		Knife / Coltello	50 x 12 x 1,5	CG01MFA310	F03FH02851
		Wedge / Cuneo	15 x 46 x 8	CN09M AP9	F03FC01290

Application examples Esempi di applicazione

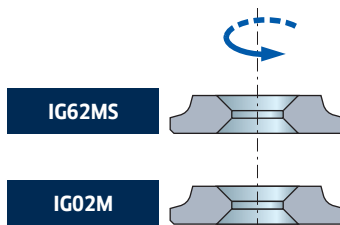
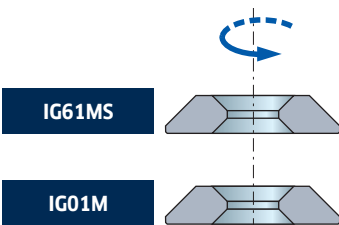
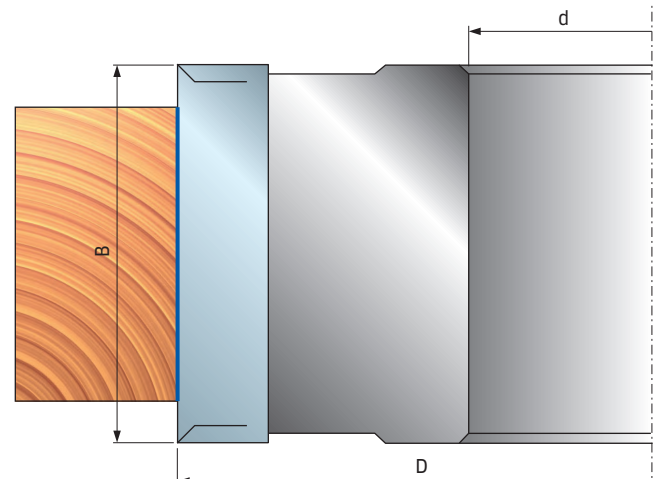
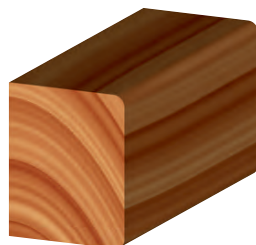
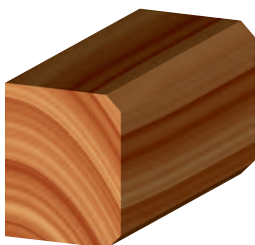
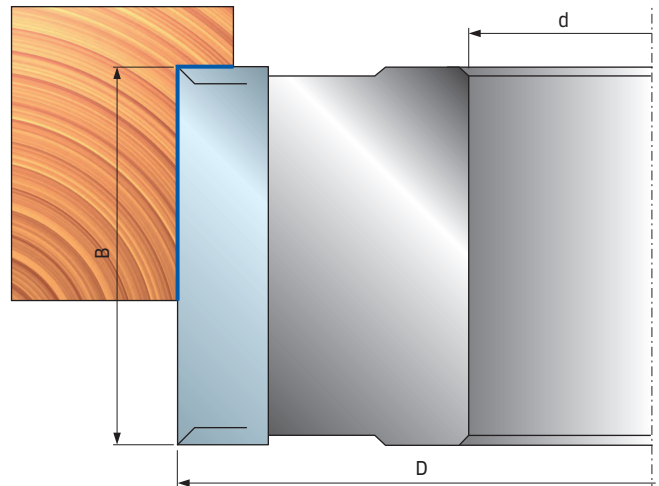
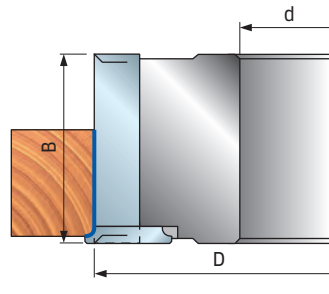
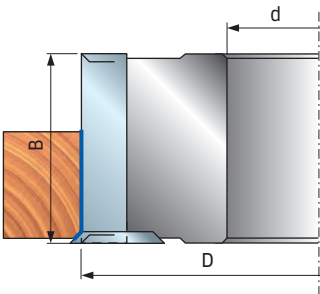

T198M

Adjustable rebate and grooves cutterheads sets with disposable knives

Gruppi di teste per incastri e battute regolabili

Tools with shear angle. Rebore not available. With seat pockets for bevelling inserts IG61MS or radius inserts IG62MS (R= 1,5; 2; 3 mm) and for grooving inserts IG04MD/S AA3 and AB3.

Utensili con angolo assiale. Non è consentita l'allargatura del foro.

Con sedi per il montaggio di inserti IG61MS (smussatori) e IG62MS (R= 1,5; 2; 3 mm) e di inserti per incastri IG04MD/S AA3 e AB3.



D mm	B-B1 mm	d mm	Z	R	Max RPM 1/min.	Code Codice	SAP SAP
140	20,5-39	30	4	4	9.600	T198M FA3	F03FC22428
140	20,5-39	32	4	4	9.600	T198M FD3	F03FC24270
140	20,5-39	35	4	4	9.600	T198M FB3	F03FC20612
140	20,5-39	40	4	4	9.600	T198M FC3	F03FC20613
140	30,4-59	30	4	4	9.600	T198M GA3	F03FC22590
140	30,4-59	32	4	4	9.600	T198M GD3	F03FC24271
140	30,4-59	35	4	4	9.600	T198M GB3	F03FC20614
140	30,4-59	40	4	4	9.600	T198M GC3	F03FC20615

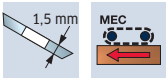

	Spare parts Parti di ricambio	Dimensions Dimensioni mm	Code Codice	SAP SAP
	Spur / Rasante	14 x 14 x 2	RG01MAA310	F03FH03034
	Nut / Ogiva	15 x 13,3 x 10	VT20M NA9	F03FC20671
	Screw / Vite	M10 x 22	VT19M MA9	F03FA04496
	Screw / Vite	M6 x 14,5	VT16M AA9	F03FA04476
	Screw / Vite	M5 x 8	VT05M AA9	F03FA04444
	Allen key / Chiave	5 x 110	CB03M EA9	F03FA00169
FA3	Spacers set / Set anelli	50 x 20 x 30	AN13M BA9	F03FC22427
FB3	Spacers set / Set anelli	55 x 20 x 35	AN13M BB9	F03FC00543
FC3	Spacers set / Set anelli	60 x 20 x 40	AN13M CB9	F03FC00545
FD3	Spacers set / Set anelli	52 x 21,1 x 32	AN13M BE9	F03FC24531
FA3	Knife / Coltello	20 x 12 x 1,5	CG01MDA310	F03FH02727
FB3	Wedge / Cuneo	15 x 16 x 8	CN09MD A09	F03FC01306
FC3	Wedge / Cuneo	15 x 16 x 8	CN09MS A09	F03FC01331
FD3	Wedge / Cuneo	15 x 16 x 8	CN09MS A09	F03FC01331
GA3	Spacers set / Set anelli	50 x 30 x 30	AN13M BD9	F03FC22591
GB3	Spacers set / Set anelli	55 x 30 x 35	AN13M BC9	F03FC00544
GC3	Spacers set / Set anelli	60 x 30 x 40	AN13M CC9	F03FC00546
GD3	Spacers set / Set anelli	52 x 31,1 x 32	AN13M BF9	F03FC24532
GA3	Knife / Coltello	30 x 12 x 1,5	CG01MEA310	F03FH02737
GB3	Wedge / Cuneo	15 x 26 x 8	CN09MD AD9	F03FC01300
GC3	Wedge / Cuneo	15 x 26 x 8	CN09MS AD9	F03FC01326
GD3	Wedge / Cuneo	15 x 26 x 8	CN09MS AD9	F03FC01326

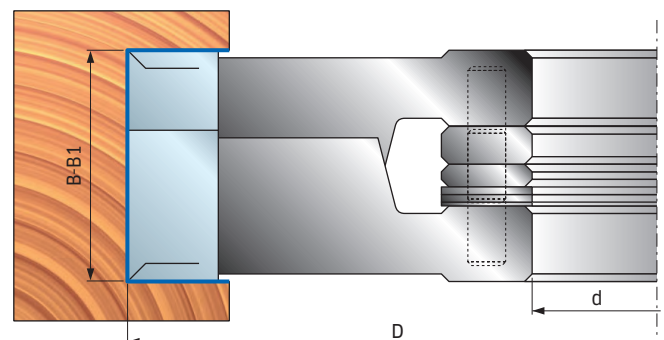
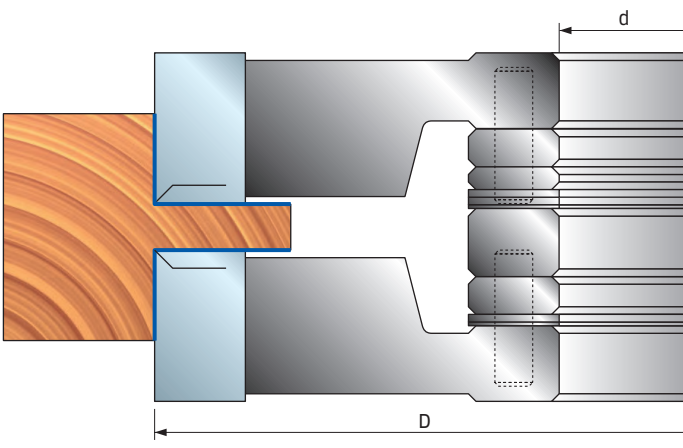
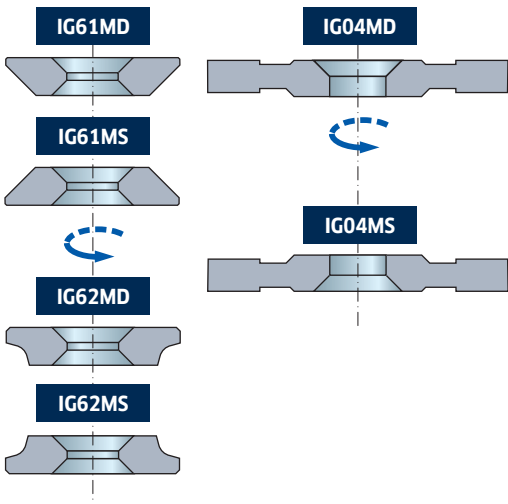

T198M

Example of profiles Esempi di profili realizzabili

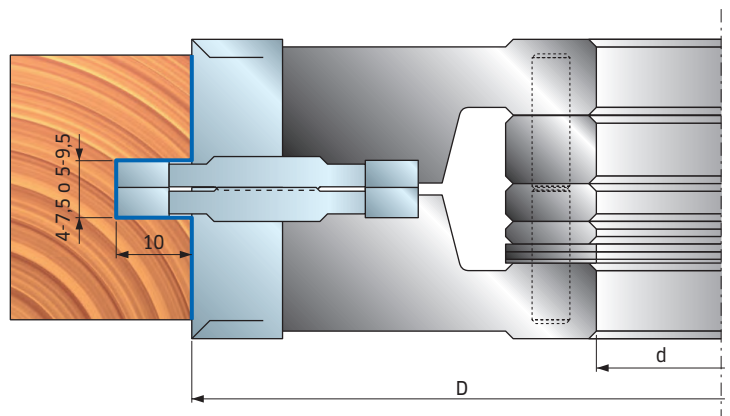
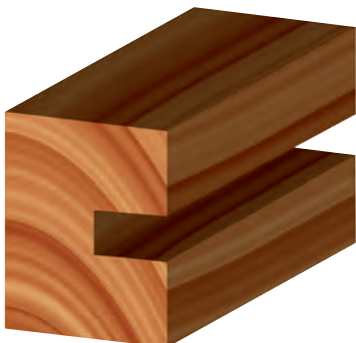
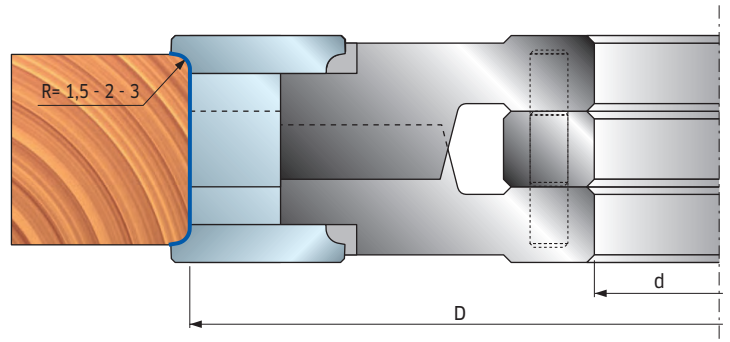
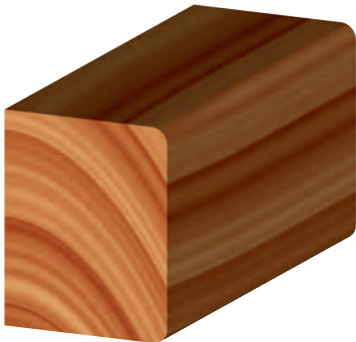
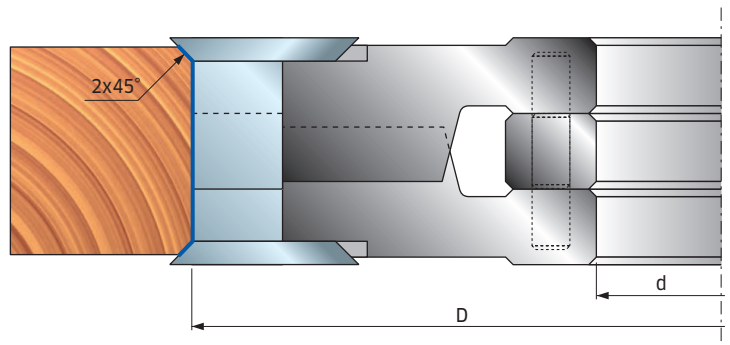
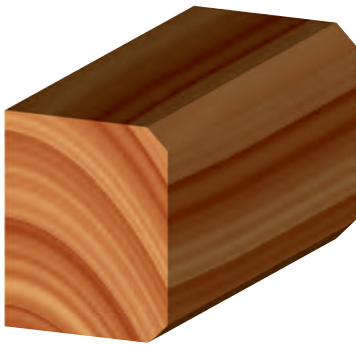
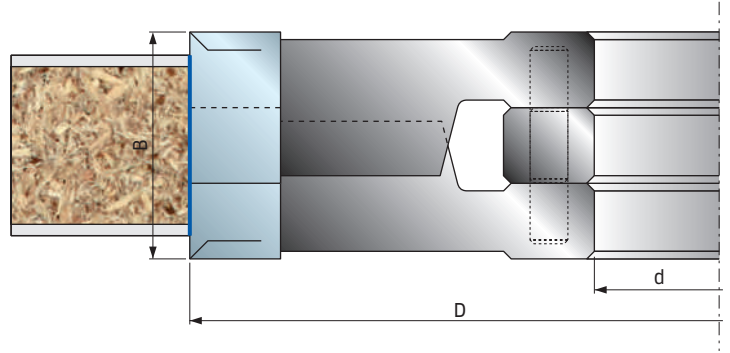

T199M

Adjustable rebate cutterheads sets with disposable knives Gruppi di teste per incastri e battute regolabili

Tools with shear angle.
Utensili con angolo assiale.

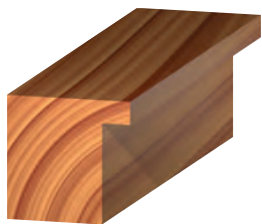
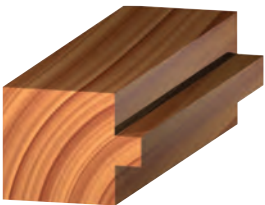
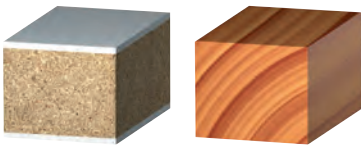
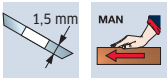

D mm	B-B1 mm	d* mm	Z	R	Max RPM 1/min.	Code Codice	SAP SAP
140	30,4-59	30 (50)	4	4	9.600	T199M GA3	F03FC20624
140	30,4-59	32 (50)	4	4	9.600	T199M GD3	F03FC24474
140	30,4-59	35 (50)	4	4	9.600	T199M GB3	F03FC20625
140	30,4-59	40 (50)	4	4	9.600	T199M GC3	F03FC20626

Spare parts Parti di ricambio		Dimensions Dimensioni mm	Code Codice	SAP SAP
	Coltello / Knife	30 x 12 x 1,5	CG01MEA310	F03FH02737
	Cuneo / Wedge	12,3 x 26 x 8	CN01MD GA9	F03FC01263
	Cuneo / Wedge	12,3 x 26 x 8	CN01MS GA9	F03FC01266
	Vite / Screw	M5 x 8	VT05M AA9	F03FA04444
	Rasante / Spur	14 x 14 x 2	RG01MAA310	F03FH03034
	Vite / Screw	M8 x 16	VT03M AA9	F03FA04435
	Chiave / Allen key	4 x 110	CB03M BA9	F03FA00163
	Allen key / Chiave	5 x 110	CB03M EA9	F03FA00169
	Torx key / Chiave Torx	T20	CB03M CC9	F03FA00167
GA3	Spacer set / Set anelli	50 x 30 x 30	AN03M AC9	F03FC00446
GB3	Spacer set / Set anelli	55 x 30 x 35	AN03M BC9	F03FC00456
GC3	Spacer set / Set anelli	60 x 30 x 40	AN03M CC9	F03FC00467
GD3	Spacer set / Set anelli	52 x 30 x 32	AN03M DC9	F03FC00475

A 10 pieces set of spacers:

Thickness: 0,1 - 0,2 - 0,3 - 0,5 - 1 - 2 - 3 - 6 - 8 - 10 mm

Set da 10 anelli:

Spessore: 0,1 - 0,2 - 0,3 - 0,5 - 1 - 2 - 3 - 6 - 8 - 10 mm

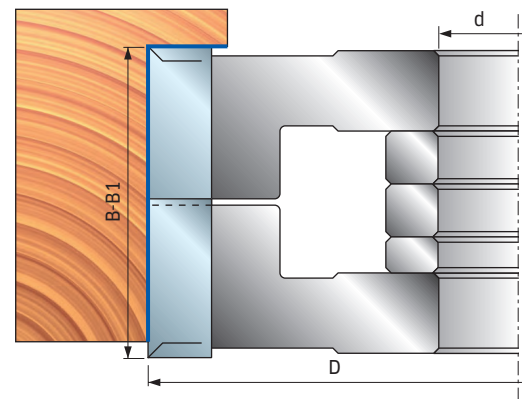
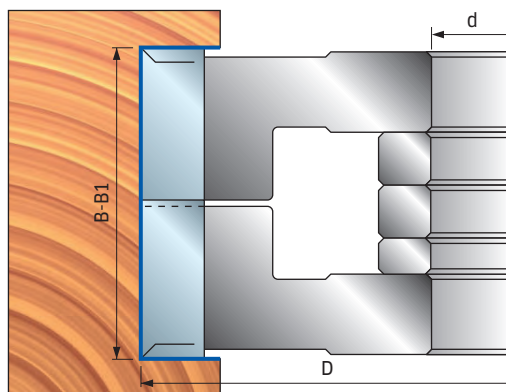
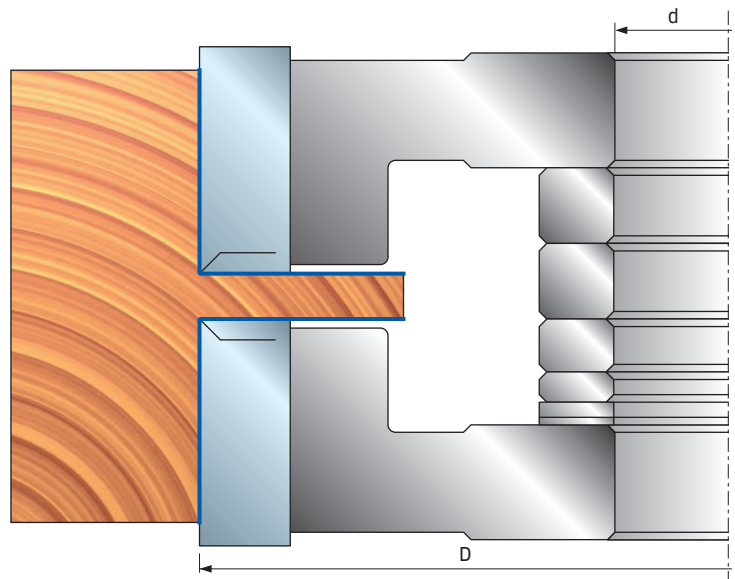

TG08M

Adjustable bevel cutterheads with disposable knives Teste ad inclinazione regolabile

Rebore not available.

Non è consentita l'allargatura del foro.

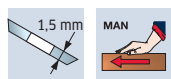

D mm	B mm	d mm	Z	R	Max RPM 1/min.	Code Codice	SAP SAP
120	40	30	2		8.500	TG08M LA3	F03FA04245
150	50	30	2		7.400	TG08M MA3	F03FA04246
150	50	35	2		7.400	TG08M MB3	F03FA04247
150	50	40	2		7.400	TG08M MC3	F03FA04248

	Spare parts Parti di ricambio	Dimensions Dimensioni mm	Code Codice	SAP SAP
	Screw / Vite	M5 x 16	2607M CF9	F03FA07367
	Screw / Vite	M6 x 8	VT03M DE9	F03FA04439
	Nut / Ogiva	12 x 12 x 6	VT20M DC9	F03FA04502
	Nut / Ogiva	12 x 10 x M5	VT20M DB9	F03FA04501
	Allen key / Chiave a "L"	3	2619M DA9	F03FA07433
	Allen key / Chiave	4 x 110	CB03M BA9	F03FA00163
ø 150 ø 120	Knife / Coltello	40 x 12 x 1,5	CG01MLA310	F03FH02872
	Wedge / Cuneo	38 x 11 x 6	CN03M DA9	F03FA00588
	Knife / Coltello	50 x 12 x 1,5	CG01MFA310	F03FH02851
	Wedge / Cuneo	48 x 11 x 6	CN03M DB9	F03FA00589

Minimum adjustment obtainable is 1 degree.

La regolazione minima ottenibile è di 1°.

Diameter Diametro mm	Inclination Inclinazione	
	Min.	Max.
120	0°	60°
150	0°	90°

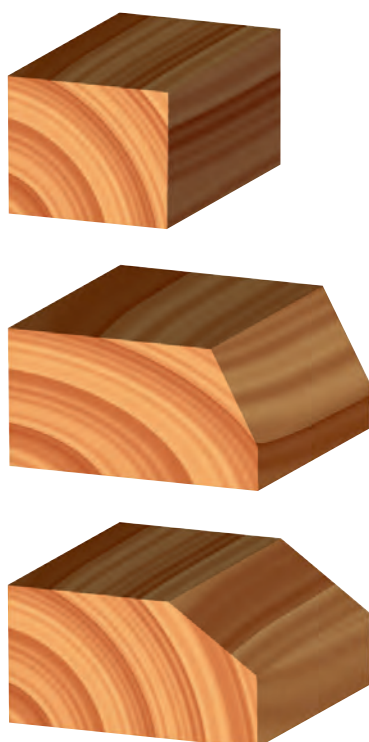
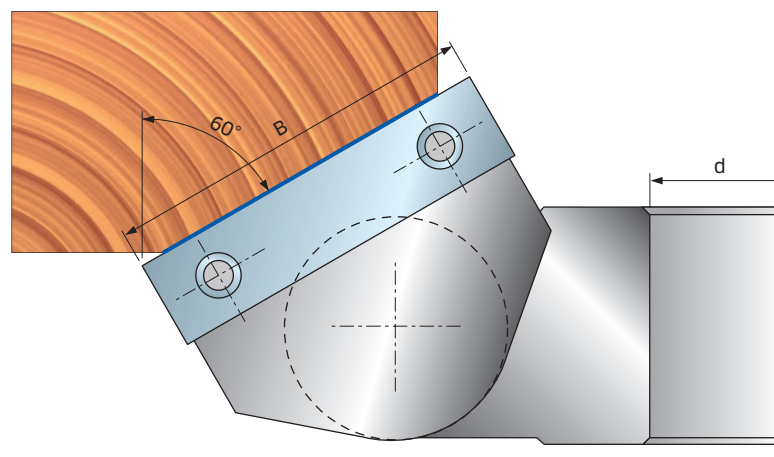
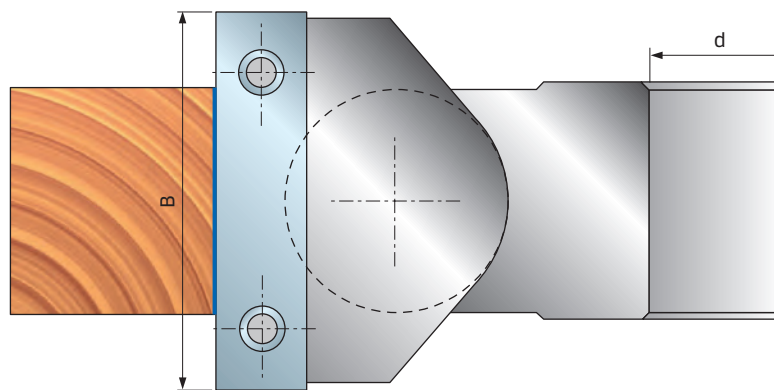
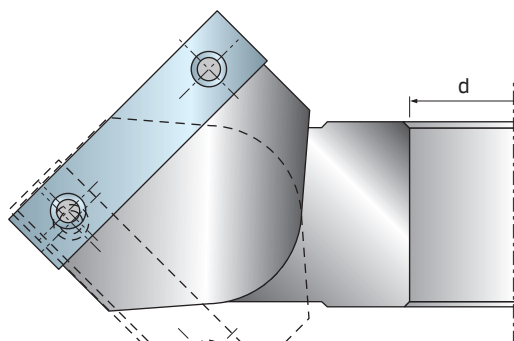

TG09M

Adjustable bevel cutterheads with disposable knives Teste ad inclinazione regolabile

Mostly suitable for chamfering on wood and composites. The particular knife locking system guarantees an angle regulation up to 90° or 75° (please refer to the drawings). Rebore not available.

Ideale per la smussatura su legno e suoi derivati.

Il particolare sistema di bloccaggio dei taglienti garantisce l'esecuzione di smussi con una regolazione dell'angolo fino a 90° o 75° (v. disegni).

Non è consentita l'allargatura del foro.

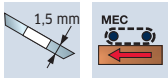

D mm	B mm	d mm	Z	R	Max RPM 1/min.	Code Codice	SAP SAP
165	50	30	2	4	6.000	TG09M AA3	F03FC23044
165	50	35	2	4	6.000	TG09M AB3	F03FC20225
165	50	40	2	4	6.000	TG09M AC3	F03FC20226
165	50	50	2	4	6.000	TG09M AD3	F03FC20227

Spare parts Parti di ricambio		Dimensions Dimensioni mm	Code Codice	SAP SAP
	Spur / Rasante	14 x 14 x 2	RG01MAA310	F03FH03034
	Screw / Vite	M5 x 8	VT05M AA9	F03FA04444
	Knife / Coltello	50 x 12 x 1,5	CG01MFA310	F03FH02851
	Screw / Vite	M6 x 16	VT03M DI9	F03FA04440

with graduated ring
con ghiera graduata

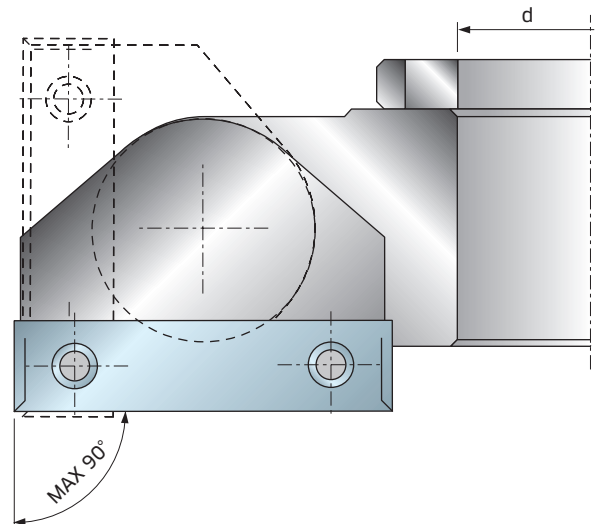
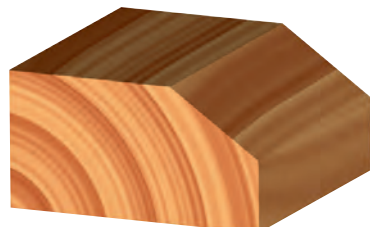
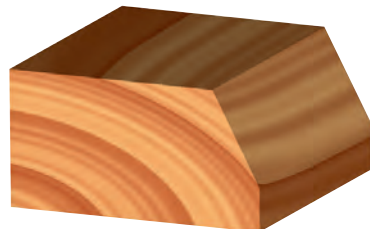
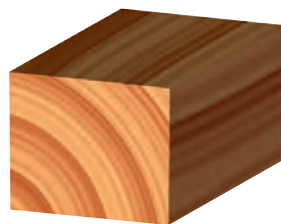
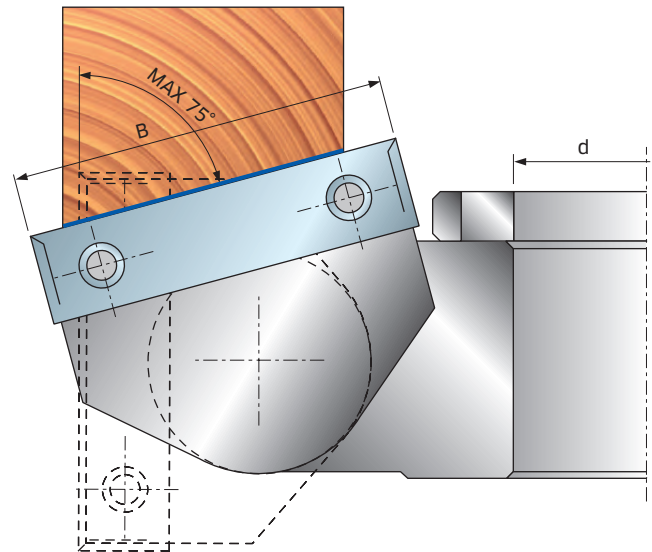
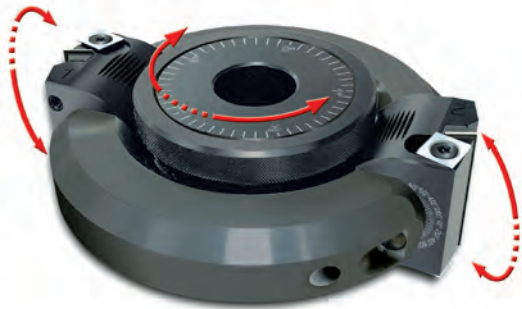

FI22M

Brazed cutters Frese per incastri

Brazed cutter with non-stick coated body. Device for patching resin pockets, cracks, damaged edges and other wood flaws.

Fresa con corpo rivestito in materiale antiaderente, utilizzata per la riparazione di sacche di resina, fessure, bordi danneggiati ed altre imperfezioni del legno.



D mm	B mm	d mm	Z	R	Max RPM 1/min.	Code Codice	SAP SAP
100	8	22	4		13.300	FI22M AB3	F03F500680

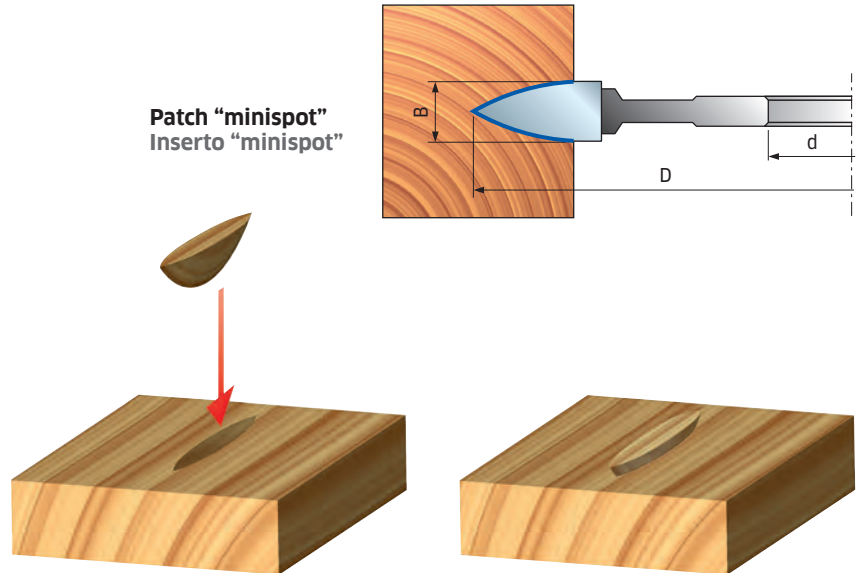
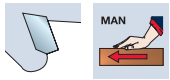

MINISPOT is a mark owned by LAMELLO AG. - Il marchio MINISPOT è di proprietà di LAMELLO AG.

FI02M

Brazed cutters for biscuit joiners Frese per incastri

Brazed cutter with anti-kickback device for good quality grooving on soft and hardwood, both cross cutting and ripping, on chipboard, compressed laminated woods and MDF.

Fresa con limitatore di truciolo per incastri di ottima qualità su legni teneri e duri lungo vena e trasverso vena; su multistrato, truciolari, laminati ed MDF.



D mm	B mm	d mm	Z	R	Max RPM 1/min.	Code Codice	SAP SAP
100	3,95	22	6		23.000	FI02M BX3	F03F500656

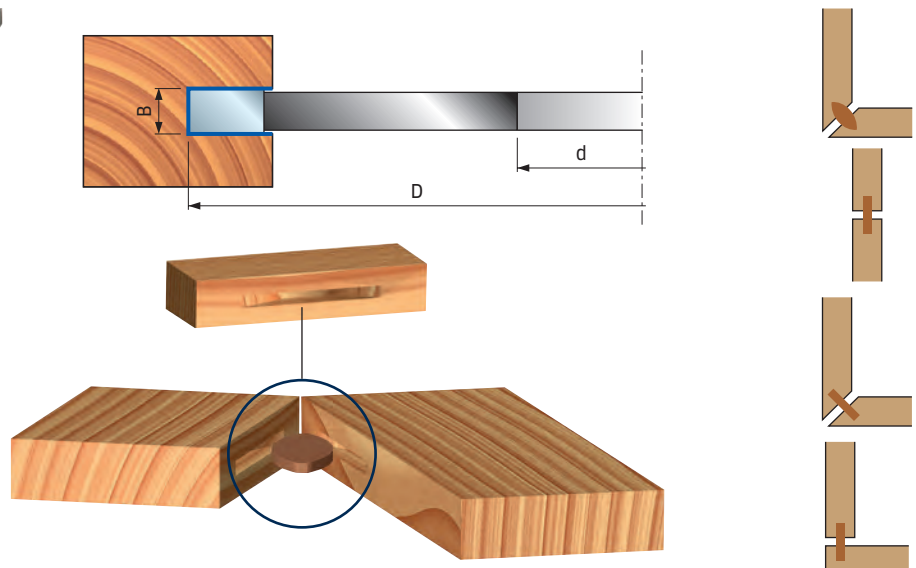
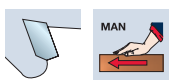

FI02M

Grooving cutters with spurs Frese per incastri con rasanti

Brazed cutter with anti-kickback device for good quality grooving on soft and hardwood, both cross cutting and ripping, on chipboard, compressed laminated woods and MDF.

Fresa con limitatore di truciolo per incastri di ottima qualità su legni teneri e duri lungo vena e trasverso vena; su multistrato, truciolari, laminati ed MDF.



D mm	B mm	d mm	Z	R	Max RPM 1/min.	Code Codice	SAP SAP
100	4	22	2	4	13.300	FI02M BZ3	F03FS00658

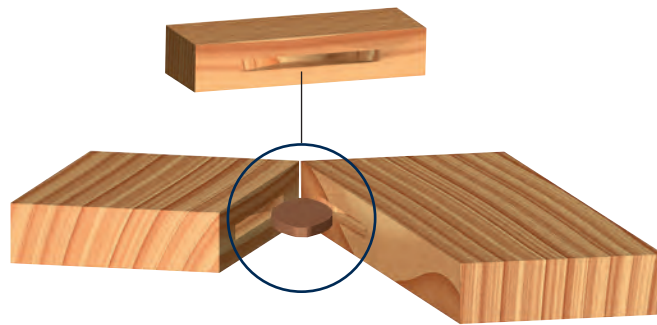
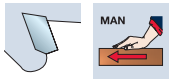
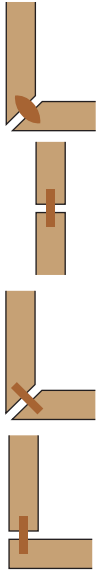
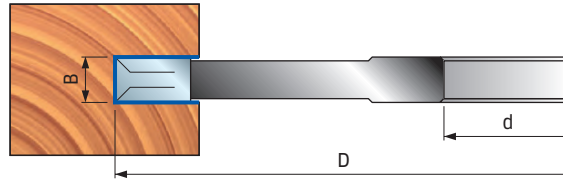

TG13M

Grooving cutterheads Teste per incastri

D mm	B mm	d mm	Z	R	Max RPM 1/min.	Code Codice	SAP SAP
100	4	22	4	4	10.500	TG13M AA3	F03FC20271



Spare parts Parti di ricambio		Dimensions Dimensioni mm	Code Codice	SAP SAP
	Coltello / Knife	18 x 1,9 x 18	CG03MAA310	F03FH02876
	Ghiera / Nut	11,6 x 1,5 x 4	VT18M BA9	F03FA04483
	Rasante / Spur	14 x 14 x 2	RG01MAA310	F03FH03034
	Ghiera / Nut	9,4 x 1,7 x 4	VT18M DA9	F03FA04487
	Vite / Screw	M4 x 3,2	VT05M BB9	F03FA04447
	Chiave Torx / Torx key	T9	CB03M CA9	F03FA00165

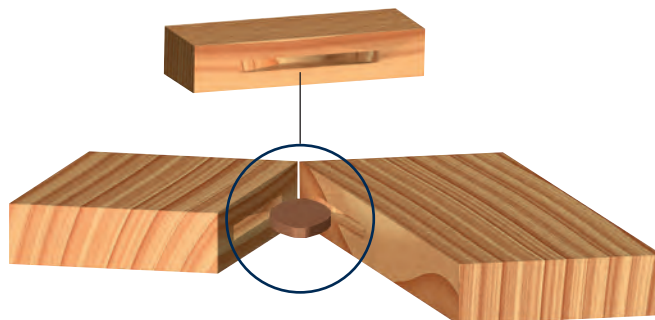
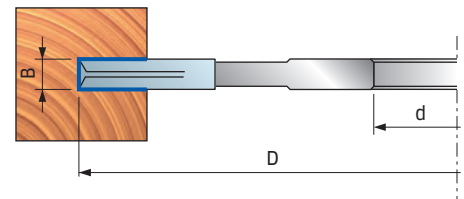
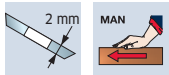

FI02M

Grooving cutters Frese per incastri

Brazed cutters for good quality grooving on soft and hardwood, both cross cutting and ripping, on chipboard, compressed laminated woods and MDF.

Frese per incastri di ottima qualità su legni teneri e duri lungo vena e trasverso vena; su multistrato, truciolari, laminati ed MDF.



D mm	B mm	d* mm	Z	R	Max RPM 1/min.	Code Codice	SAP SAP
120	4	35 (40)	6		12.000	FI02M CD3	F03FS00659
120	6	35 (40)	6		12.000	FI02M CI3	F03FS00660
140	4	35 (50)	6		10.000	FI02M FE3	F03FS00661
140	6	35 (50)	6		10.000	FI02M FN3	F03FS00662
140	8	35 (50)	6		10.000	FI02M FS3	F03FS00663
140	10	35 (50)	6		10.000	FI02M FY3	F03FS00664
140	12	35 (40)	6		10.000	FI02M GB3	F03FC07393
140	14	35 (40)	6		10.000	FI02M GF3	F03FC07400
140	16	35 (40)	6		10.000	FI02M GK3	F03FC07406
140	18	35 (40)	6		10.000	FI02M GN3	F03FC07409
140	20	35 (40)	6		10.000	FI02M GP3	F03FC07413

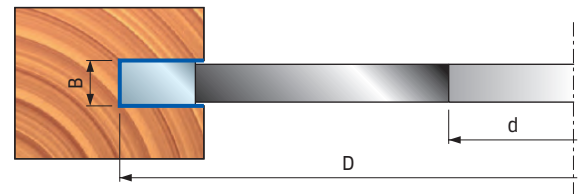
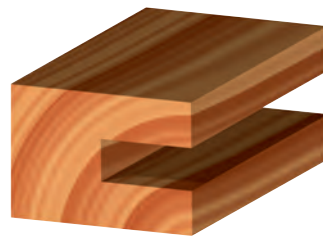
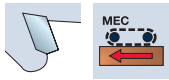

FI05M

Grooving cutters with spurs Frese per incastri con rasanti

Brazed cutters for good quality grooving on soft and hardwood, both cross cutting and ripping, on chipboard, compressed laminated woods and MDF.

Frese per incastri di ottima qualità su legni teneri e duri lungo vena e trasverso vena; su multistrato, truciolari, laminati ed MDF.



D mm	B mm	d* mm	Z	R	Max RPM 1/min.	Code Codice	SAP SAP
140	4	35 (50)	3	6	10.000	FI05M EB3	F03FC07525
140	6	35 (50)	3	6	10.000	FI05M EH3	F03FC07533
140	8	35 (50)	3	6	10.000	FI05M EN3	F03FC07539
140	10	35 (50)	3	6	10.000	FI05M ER3	F03FC07545

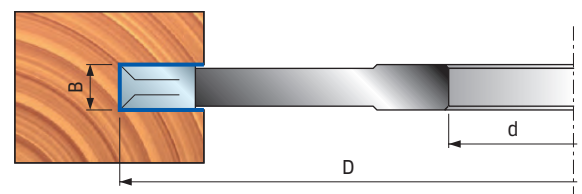
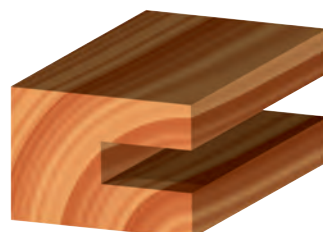
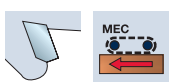

* Size shown between brackets is the max. rebore possible • La quota tra parentesi è la massima allargatura foro possibile

FI14M

Grooving cutters Frese per incastri

Brazed cutters for good quality grooving on soft and hardwood, both cross cutting and ripping, on chipboard, compressed laminated woods and MDF.

Frese per incastri di ottima qualità su legni teneri e duri lungo vena e trasverso vena; su multistrato, truciolari, laminati ed MDF.



D mm	B mm	d* mm	Z	R	Max RPM 1/min.	Code Codice	SAP SAP
150	1,5	30 (50)	18		14.500	FI14M AA3**	F03FS00665
150	2	30 (50)	18		14.500	FI14M AE3	F03FS00667
150	2,5	30 (50)	18		14.500	FI14M AH3	F03FS00668
150	3	30 (50)	18		14.500	FI14M AM3	F03FS00669
150	4	30 (50)	18		14.500	FI14M AR3	F03FS00670
150	5	30 (50)	18		14.500	FI14M AZ3	F03FS00673
180	3	30 (50)	24		11.500	FI14M DA3	F03FS00677
180	4	30 (50)	24		11.500	FI14M DC3	F03FS00678

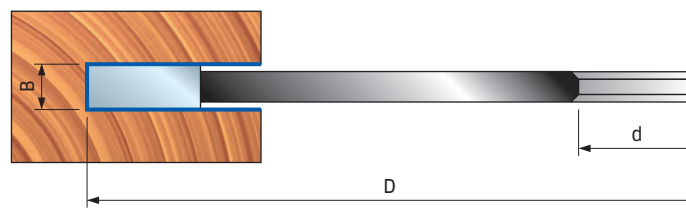
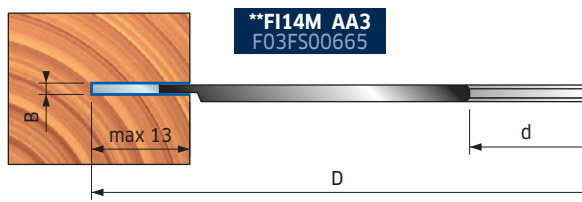
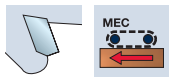

FI07M

Adjustable grooving cutters with spurs Frese regolabili per incastri con rasanti

Brazed cutters for good quality adjustable grooving on soft and hardwood, both cross cutting and ripping, on chipboard, compressed laminated woods and MDF. Adjustable with spacers.

Frese per incastri regolabili di ottima qualità su legni teneri e duri lungo vena e trasverso vena; su multistrato, truciolari, laminati ed MDF. Regolazione con anelli.



D mm	B mm	d* mm	Z	R	Max RPM 1/min.	Code Codice	SAP SAP
150	3 - 5,5	35 (50)	4	4	9.400	FI07M AB3	F03FC07629
150	4 - 7,5	35 (50)	4	4	9.400	FI07M AE3	F03FC07634
150	7,5 - 14	35 (50)	4	4	9.400	FI07M AL3	F03FC07643
160	10 - 19	35 (50)	4	4	9.000	FI07M BB3	F03FC07655

Depth of cut
Profondità
d'incastro

L mm	D mm
27	150
32	160

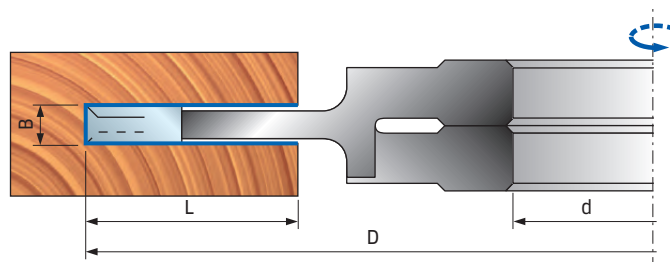
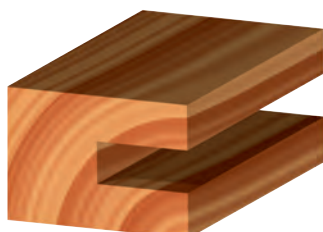
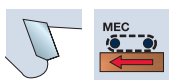

TG11M

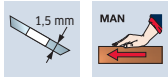
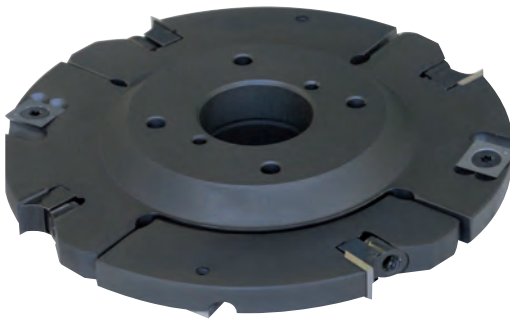

Depth of cut - Profondità d'incastro

L mm	D mm
30	160
40	200

Spare spacers set - Set anelli di ricambio

Dimensions Dimensioni mm	Code Codice	SAP SAP
50 x 0,1 x 30	AN01MA0019	F03FC00030
50 x 0,2 x 30	AN01MA0029	F03FC00031
50 x 0,5 x 30	AN01MA0059	F03FC00033
50 x 8 x 30	AN03M AH9	F03FC00451
50 x 4 x 30	AN03M AF9	F03FC00449
50 x 12 x 30	AN03M AI9	F03FC00452
52 x 0,1 x 32	AN01MX0019	F03FC24484
52 x 0,2 x 32	AN01MX0029	F03FC24485
52 x 0,5 x 32	AN01MX0059	F03FC24487
52 x 8 x 32	AN03M GF9	F03FC24529
52 x 4 x 32	AN03M GE9	F03FC24528
52 x 12 x 32	AN03M GG9	F03FC24530
55 x 0,1 x 35	AN01MB0019	F03FC00081
55 x 0,2 x 35	AN01MB0029	F03FC00082
55 x 0,5 x 35	AN01MB0059	F03FC00084
55 x 8 x 35	AN03M BH9	F03FC00461
55 x 4 x 35	AN03M BF9	F03FC00459
55 x 12 x 35	AN03M BI9	F03FC00462
60 x 0,1 x 40	AN01MC0019	F03FC00123
60 x 0,2 x 40	AN01MC0029	F03FC00124
60 x 0,5 x 40	AN01MC0059	F03FC00126
60 x 8 x 40	AN11M CH9	F03FC00532
60 x 4 x 40	AN11M CF9	F03FC00531
60 x 12 x 40	AN11M CI9	F03FC00533

Adjustable grooving cutterheads Teste per incastri regolabili

D mm	B-B1 mm	d* mm	Z	R	Max RPM 1/min.	Code Codice	SAP SAP
160	4 - 7,5	30	8	4	8.300	TG11M AA3	F03FC20228
160	4 - 7,5	32	8	4	8.300	TG11M AE3	F03FC24417
160	4 - 7,5	35	8	4	8.300	TG11M AB3	F03FC20229
160	4 - 7,5	40	8	4	8.300	TG11M AC3	F03FC20230
160	8 - 15,5	30	4	4	8.300	TG11M DA3	F03FC20232
160	8 - 15,5	32	4	4	8.300	TG11M DE3	F03FC24418
160	8 - 15,5	35	4	4	8.300	TG11M DB3	F03FC20233
160	8 - 15,5	40	4	4	8.300	TG11M DC3	F03FC20234
160	12,5 - 24	30	4	4	8.300	TG11M TA3	F03FC20237
160	12,5 - 24	32	4	4	8.300	TG11M TE3	F03FC24419
160	12,5 - 24	35	4	4	8.300	TG11M TB3	F03FC20238
160	12,5 - 24	40	4	4	8.300	TG11M TC3	F03FC20239
200	4 - 7,5	32	8	4	6.600	TG11M FE3	F03FC24420
200	4 - 7,5	35 (50)	8	4	6.600	TG11M FB3	F03FC20235
200	8 - 15,5	35 (50)	4	4	7.000	TG11M HB3	F03FC20236
200	12,5 - 24	35 (50)	4	4	7.000	TG11M VB3	F03FC20240

	Spare parts Parti di ricambio	Dimensions Dimensioni mm	Code Codice	SAP SAP
AA3 - AB3 AC3 - AE3	Torx key / Chiave Torx	T20	CB03M CC9	F03FA00167
	Knife / Coltello	18 x 1,9 x 18	CG03MAA310	F03FH02876
	Screw / Vite	M4 x 3,2	VT05M BB9	F03FA04447
	Threaded rings / Ghiera	11,6 x 1,5 x 4	VT18M BA9	F03FA04483
DA3 - DB3 DC3 - DE3	Threaded rings / Ghiera	9,4 x 1,7 x 4	VT18M DA9	F03FA04487
	Torx key / Chiave Torx	T9	CB03M CA9	F03FA00165
	Knife / Coltello	7,6 x 12 x 1,5	CG01MAA310	F03FH01543
	Wedge / Cuneo	15 x 7,2 x 8	CN09M DA9	F03FC01295
TA3 - TB3 TC3 - TE3	Spur / Rasante	14 x 14 x 2	RG01MAA310	F03FH03034
	Screw / Vite	M5 x 6	VT05M AC9	F03FA04446
	Screw / Vite	M5 x 19	VT11M AA9	F03FA04468
	Allen key / Chiave a "L"	2,5	2619M CA9	F03FA07432
	Torx key / Chiave Torx	T9	CB03M CA9	F03FA00165
	Knife / Coltello	12 x 12 x 1,5	CG01MBA310	F03FH01636
	Wedge / Cuneo	15 x 10 x 8	CN09M AA9	F03FC01280
	Screw / Vite	M5 x 8	VT05M AA9	F03FA04444
	Screw / Vite	M6 x 22	VT19M AB9	F03FA04491
	Nut / Ogiva	10 x 11,5 x 6	VT20M AA9	F03FA04497
	Allen key / Chiave	3 x 110	CB03M AA9	F03FA00162

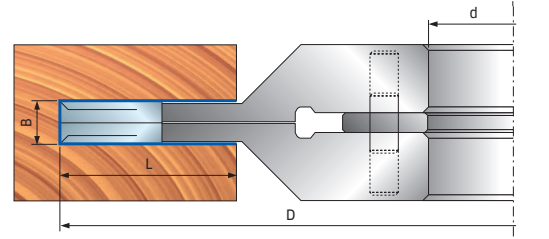
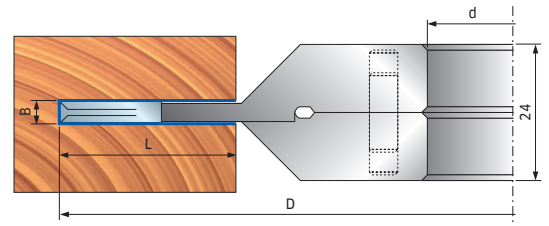
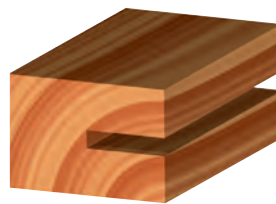

* Size shown between brackets is the max. rebore possible • La quota tra parentesi è la massima allargatura foro possibile

TG18MG

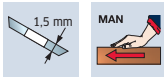

Adjustable grooving cutterheads sets Gruppi di teste per incastrati regolabili

D mm	B-B1 mm	d* mm	Z	R	Max RPM 1/min.	Code Codice	SAP SAP
160	4-15	30			8.500	TG18MG AA3	F03FC24546
160	4-15	32			8.500	TG18MG AE3	F03FC24549
160	4-15	35			8.500	TG18MG AB3	F03FC24547
160	4-15	40			8.500	TG18MG AC3	F03FC24548
160	8-23	30			8.500	TG18MG DA3	F03FC24550
160	8-23	32			8.500	TG18MG DE3	F03FC24553
160	8-23	35			8.500	TG18MG DB3	F03FC24551
160	8-23	40			8.500	TG18MG DC3	F03FC24552
160	12,5-31,5	30			8.500	TG18MG TA3	F03FC24554
160	12,5-31,5	32			8.500	TG18MG TE3	F03FC24557
160	12,5-31,5	35			8.500	TG18MG TB3	F03FC24555
160	12,5-31,5	40			8.500	TG18MG TC3	F03FC24556

	Spare parts Parti di ricambio	Dimensions Dimensioni mm	Code Codice	SAP SAP
AA3 - AB3 AC3 - AE3	Knife / Coltello	18 x 1,9 x 18	CG03MAA310	F03FH02876
	Screw / Vite	M4 x 3,2	VT05M BB9	F03FA04447
	Threaded rings / Ghiera	11,6 x 1,5 x 4	VT18M BA9	F03FA04483
	Threaded rings / Ghiera	9,4 x 1,7 x 4	VT18M DA9	F03FA04487
	Torx key / Chiave Torx	T9	CB03M CA9	F03FA00165
DA3 - DB3 DC3 - DE3	Knife / Coltello	7,6 x 12 x 1,5	CG01MAA310	F03FH01543
	Wedge / Cuneo	15 x 7,2 x 8	CN09M DA9	F03FC01295
	Spur / Rasante	14 x 14 x 2	RG01MAA310	F03FH03034
	Screw / Vite	M5 x 6	VT05M AC9	F03FA04446
	Screw / Vite	M5 x 19	VT11M AA9	F03FA04468
	Fork wrench / Chiave a forchetta	5	CB04M 059	F03FA00172
TA3 - TB3 TC3 - TE3	Knife / Coltello	12 x 12 x 1,5	CG01MBA310	F03FH01636
	Wedge / Cuneo	15 x 10 x 8	CN09M AA9	F03FC01280
	Screw / Vite	M5 x 8	VT05M AA9	F03FA04444
	Screw / Vite	M6 x 22	VT19M AB9	F03FA04491
	Nut / Ogiva	10 x 11,5 x 6	VT20M AA9	F03FA04497
	Allen key / Chiave	3 x 110	CB03M AA9	F03FA00162

	Spare spacers set Set anelli di ricambio	Dimensions Dimensioni mm	Code Codice	SAP SAP
	Spacers set / Set anelli	50 x 7,6 x 30	AN03M AN9	F03FC24566
	Spacers set / Set anelli	55 x 7,6 x 35	AN03M BQ9	F03FC24567
	Spacers set / Set anelli	55 x 7,6 x 40	AN11M CL9	F03FC24568
	Spacers set / Set anelli	52 x 7,6 x 32	AN03M GH9	F03FC24569
	Spacers set / Set anelli	50 x 11,6 x 30	AN03M AO9	F03FC24570
	Spacers set / Set anelli	55 x 11,6 x 35	AN03M BR9	F03FC24571
	Spacers set / Set anelli	55 x 11,6 x 40	AN11M CM9	F03FC24572
	Spacers set / Set anelli	52 x 11,6 x 32	AN03M GI9	F03FC24573
	Spacers set / Set anelli	50 x 15,6 x 30	AN03M AP9	F03FC24574
	Spacers set / Set anelli	55 x 15,6 x 35	AN03M BS9	F03FC24575
	Spacers set / Set anelli	55 x 15,6 x 40	AN11M CN9	F03FC24576
	Spacers set / Set anelli	52 x 15,6 x 32	AN03M GL9	F03FC24577

* Size shown between brackets is the max. rebore possible • La quota tra parentesi è la massima allargatura foro possibile

TG18MG

Example of profiles
Esempi di profili realizzabili

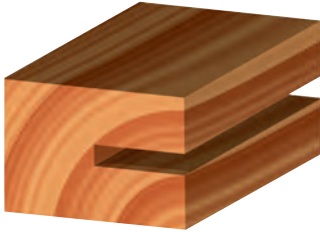

TG18M AA3
AE3 - AB3 - AC3

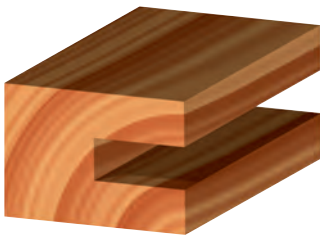
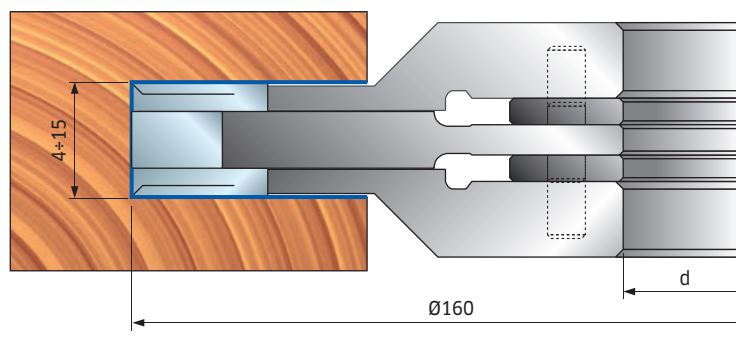

TG18M DA3
DE3 - DB3 - DC3

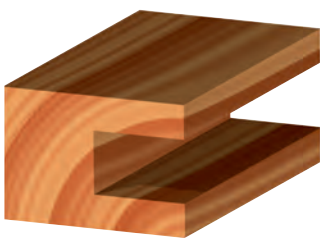
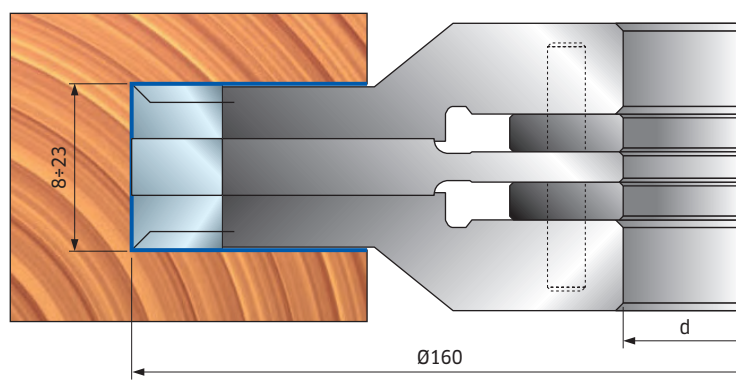

TG18M TA3
TE3 - TB3 - TC3

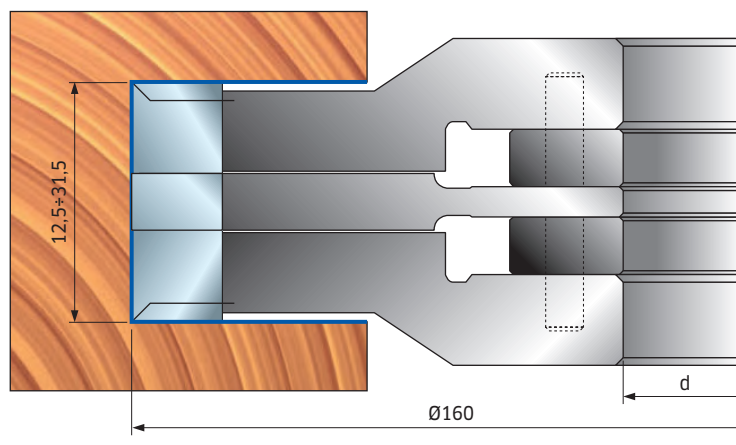

freud.

freud S.p.A.
Società Unipersonale
Via Padova, 3
33010 Tavagnacco (UD) IT
Tél. +39 0432 551411
Fax +39 0432 551440
info@freud.it
www.freud.it

DISTRIBUTER ZA SRBIJU

GATECH

DUČEVAC 15 - 11260 UMKA - SRBIJA

☎ 011/802-70-70 ✉ info@gatech.rs

www.gatech.rs